

Quattroflow Q-Control Operating Manual

Supplement to original Operating Manuals for Quattroflow Pumps

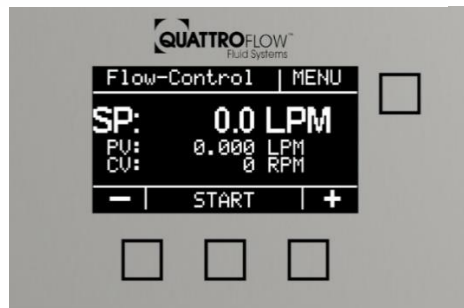

Operator and Control Unit for Quattroflow pump types:
QF30QCON QF150QCON QF1200QCON
QF2500QCON QF4400QCON QF5KQCON

Operating Manual Revision 1

Valid for Q-Control Firmware-Version 02.XX.XX

PSG Germany GmbH

Hochstraße 150-152

47228 Duisburg, Germany

Phone +49 (0) 2065 89205-0

Fax: +49 (0) 2065 89205-40

Email: psg-germany@psgdover.com

Internet: www.quattroflow.com

Keep this Operating Manual on hand near the device.

Include it if the device is sold

.

- **Note**

Follow warning and safety instructions!



→ Please read this Operating Manual carefully prior to first use and instruct operating personnel accordingly.

Contents

1	Notes on reading	9
	1.1 Abbreviations, synonyms, symbols for this manual	9
	1.2 Risk mitigation by means of user information	9
	1.3 Technical Documentation	11
2	Legal provisions	12
	2.1 Directives and standards applied	12
	2.1.1 Evaluation of conformity	12
	2.2 Exclusion of Liability	12
	2.2.1 Modifications	12
3	 Safety	13
	3.1 Intended use	13
	3.1.1 Reasonably anticipated incorrect use	13
	3.2 Safety instructions	14
	3.2.1 Label on the device	16
	3.3 Operator	17
	3.4 Personnel	17
	3.4.1 Description of user groups	17
	3.4.2 Limited access	19
4	Transport, storage, installation, decommissioning, disposal, recommissioning	20
	4.1 Transport	20
	4.2 Storage	20
	4.3 Assembly	20
	4.4 Decommissioning	20
	4.5 Disposal	21
	4.5.1 Note on battery disposal	21
	4.6 Recommissioning	22
5	Installation	23
	5.1 Electrical connection	23
	5.2 Digital inputs	23

5.3	Analog inputs	23
5.4	Analog output.....	24
5.5	Digital output.....	24
5.6	Battery.....	24
5.7	USB.....	24
5.8	Signal connections and wiring	25
5.8.1	Type and pin-allocation.....	25
5.8.2	Port X1	26
5.8.3	Port X2.....	27
5.8.4	Port X3.....	27
5.8.5	Port X4.....	29
5.8.6	Port X5.....	29
5.8.7	Port RS485	30
6	Maintenance	31
6.1	Warning notices	31
6.2	Inspections.....	31
6.2.1	Check safety equipment regularly	31
6.3	Maintenance	32
6.3.1	Changing the battery	32
6.4	Errors and trouble shooting	33
6.5	RMA process	35
7	General operation and menu structure.....	36
7.1	Display and softkeys.....	36
7.2	Navigation.....	38
7.2.1	Main window	38
7.2.2	Selecting the operating mode	38
7.2.3	Settings (configuration).....	38
7.3	User levels, login, and PIN	40
7.1	Menu structure and brief description of settings.....	41
8	Usage of analog and digital sensors	46
8.1	Using sensors with analog signal	46
8.1.1	Basic configuration of the analog input.....	46
8.1.2	Assign sensor as master sensor for the operating modes	48
8.2	Using sensors with a digital signal.....	49

9	Use of the integrated signal processing for em-tec flow sensors and PendoTECH pressure sensors and other special sensors (optional)	50
9.1	Integrated signal processing for em-tec clamp on flow sensors – Only for SU Pumps with code QCON...-E and QCON...-EP with Firmware 02.XX.XX	50
9.1.1	General information	50
9.1.2	Connection to the pump.....	51
9.1.3	Selection of the hose and sensor installation to the hose	51
9.1.4	Parameterization of Q-Control	53
9.1.5	Scaling of measurement range and analog signal for the flow measurement.....	54
9.1.6	Use of the RSS-Value.....	57
9.1.7	Use of the em-tec Sensor (zeroing and measurement)	58
9.1.8	Errors, trouble shooting	60
9.1.9	FlowMCP-a Web interface.....	62
9.1.10	Cleaning and disinfection of the sensor.....	63
9.2	Integrated signal processing for PendoTECH Pressure Sensors – Only for SU Pumps with code QCON...-P and QCON...-EP with Firmware 02.XX.XX.....	64
9.2.1	General information	64
9.2.2	Connection to the pump.....	64
9.2.3	Parameterization of Q-Control	65
9.2.4	Scaling of measurement range and analog signal	66
9.2.5	Notes on sensor selection and installation	67
9.2.6	Use of the PendoTECH Sensors (zeroing and measurement)	68
9.2.7	Errors and troubleshooting	70
9.3	Pressure sensor Labom Pascal CS2110 (multiple-use).....	71
9.3.1	General information	71
9.3.2	Commissioning and parameterization	72
9.4	Flow sensor em-tec BioProTT Clamp-On / FlowTrack plus	73
9.4.1	General information	73
9.4.2	Commissioning and parameterization	75
9.4.3	Option: Using RSS-value (only special with Y-cable).....	76
9.5	Diaphragm monitoring (multiple-use and single-use).....	77
9.5.1	General information	77
9.5.2	Commissioning and parameterization	78
10	Operating modes (description, configuration, and use).....	79
10.1	Manual RPM (rotation speed).....	81
10.1.1	Installation.....	81
10.1.2	Use.....	81

10.1.3	Option: Display sensor value	82
10.1.4	Option: Totalizer	83
10.1.5	Option: Display of RSS value for em-tec flow sensors	83
10.2	Manual flow	84
10.2.1	Installation	84
10.2.2	Configuration	84
10.2.3	Use	84
10.2.4	Option: Totalizer	85
10.3	External UPM (rotation speed via an external remote control)	86
10.3.1	Installation	86
10.3.2	Configuration	86
10.3.3	Use	87
10.3.4	Scaling	87
10.4	Dispensing	89
10.4.1	Installation	89
10.4.2	Configuration	89
10.4.3	Use	91
10.4.4	Example application: Dispense	92
10.5	Flow control and pressure control	94
10.5.1	Installation	94
10.5.2	Configuration	94
10.5.3	Use	94
10.5.1	Option: Display of RSS value for em-tec flow sensors	96
10.5.2	PID values and Autotune	97
10.5.3	Influence of the Slope parameter on the controller and autotune	103
10.5.4	Influence of filter time on the controller and autotune	103
10.5.5	PID Error for Options em-tec / PendoTECH	103
10.5.6	Example application: Filtration with pressure control	105
10.5.7	Example application: Flow control with tangential flow filtration	106

11 Alarms 107

11.1	Process alarms (can be activated by the user)	107
11.1.1	Process Alarms for analog inputs	107
11.1.2	Process alarms digital inputs	109
11.1.3	Influence of a filter time on the process alarms	110
11.1.4	Special process alarm: Pressure shut-off	110
11.2	Sensor alarms and sensor monitoring	111
11.2.1	Sensor-Alarm analog inputs	111
11.2.2	Sensor-Alarm Digital inputs	113

12 Integrated functions 114

12.1	Totalizer	114
12.1.1	Internal	114

12.1.2	Sensor.....	115
12.2	Calibration factor / displacement volume (Cal).....	116
12.2.1	Determining the calibration factor	117
12.2.2	Standard values	118
12.2.3	Influence of the calibration factor on the dispensing operating mode	118
12.3	Maximum Values (user limits).....	120
12.3.1	Influence of Max RPM in the Manual flow operating mode	121
12.3.2	Influence of the parameter Max RPM on the Dispensing operating mode	122
12.4	Slope (motor acceleration).....	123
12.5	External start/stop	126
12.5.1	Function of the parameter External Trigger	128
12.5.2	Function of External start/stop in all operating modes	130
12.6	Signal outputs	131
12.6.1	Analog output (AO)	131
12.6.2	Digital output (DO)	132
12.7	Screensaver.....	133
12.8	Display of the analog-input values during operation	134
13	USB Logging.....	135
13.1	General information	135
13.2	Configuration	136
13.3	Recording format	137
14	Saving and loading configuration (parameterization)	139
14.1	General information	139
14.2	Use.....	140
14.3	Compatibility of the configuration	141
14.4	Factory Settings and Factory Reset	143
15	Firmware update (Software)	144
15.1	Important Information about Firmware Update.....	144
15.2	Procedure for Firmware Update	145
15.3	Loading of Standard-Configuration (only for FW 01.XX.XX)	146
16	RS485 Modbus.....	147
16.1	Configuration	147
16.2	Modbus register	147

16.3	Functional principle	147
17	Option: Conversation between QF30QCON / QF150QCON	148
17.1	Overview	148
17.2	Retrofitting by the user.....	148
17.3	Notes for Function Factory Reset.....	149
18	Technical Documentation	150
18.1	Technical data Q-Control	150
18.1.1	Panel	150
18.1.2	Specification connections	150
18.1.3	Special operating elements (em-tec / PendoTECH option).....	152
18.1.4	Inputs	153
18.1.5	Outputs	153
18.1.6	USB port	154
18.1.7	RS485 Modbus	154
18.1.8	Outputs for internal use	154
18.1.9	Integrated evaluation unit for connecting em-tec flow sensors (option).....	155
18.1.10	Integrated evaluation unit for connecting PendoTECH pressure sensors (option)	155
18.2	Parameter table and standard values.....	156
18.3	Predefined manufactory parameters	159
19	Units and abbreviations	160
20	Revision history operating manual	161
21	Notes	162

1 Notes on reading

- Note**

Quattroflow 4-piston membrane pump models QF30Qcon, QF150Qcon, QF1200Qcon, QF2500Qcon, and QF4400Qcon are equipped with a control device, referred to below as “Q-Control.” The control device is preconfigured as standard and includes the connecting cables required for commissioning the pump.

This Operation Manual for the control device is a supplement to the Operation Manual for the standard pumps. All information in the Operation Manual for the pump, especially the warning and safety instructions, also apply here and must be read carefully and followed prior to commissioning.

- Prior to making electrical connections to the pump motor and the power supply, check to make sure the cables are not damaged.
- Plug in the cable firmly before closing the lock.

1.1 Abbreviations, synonyms, symbols for this manual

Abbreviation / Synonym	Meaning
Device	Q-Control
PPE	Personal protective equipment

Symbol	Meaning
→	Instructions
●	List
	Request to read additional documents
Italics	Indicates a button, key, or switch

1.2 Risk mitigation by means of user information

According to § 3 of the law on liability for defective products (ProdHaftG), a product is defective “*if it does not provide the safety that can reasonably be expected under consideration of all circumstances, particularly its presentation, its reasonably expected use, and the point in time at which it was put on the market.*”

The user information in the form of instructions or the Operation Manual is part of the presentation of a product. It must include all relevant information for safe use over the entire service life of the product. This includes the intended use and foreseeable misuse, including emergency measures.

The directives, standards, and regulations that relate to the product can contain requirements for the contents of user information.

In addition to potential Type C standards, the directives, standards, and regulations include, for example:

- 2006/42/EC – Machinery Directive, Annex I, Section 1.7.4
- EN ISO 12100 – Safety of machinery - General principles for design - Risk assessment and risk reduction
- EN 82079-1 – Preparation of instructions for use - Structuring, content and presentation - Part 1: General principles and detailed requirements
- EN ISO 20607 – Safety of machinery - Instruction handbook - General drafting principles

Section Safety

This section provides information about measures to be taken for your safety. The information is intended to promote awareness of safe behavior. The objective is to provide a basis for training sessions and instructions

Notice of residual risks

Safe use includes awareness of existing residual risks. Instructions and manuals must provide clear information about potential residual risks that may still be present after risk reductions have been completed. The standard EN 82079-1 sets requirements for the content and presentation of residual risks. Three hazard classifications are differentiated for the description of residual risks, and they are visualized with signal words and associated symbols.

Signal word	Level of risk of the hazard	Meaning
• DANGER	high	Death or severe injury will occur if the hazard is not avoided.
• WARNING	medium	Death or severe injury can occur if the hazard is not avoided.
• CAUTION	low	Slight or moderate injury can occur if the hazard is not avoided.
• NOTE	Not safety-related	General instructions and user tips and recommended practices for efficient, trouble-free operation.

The safety-related information tells about the hazards of the device and how to avoid the hazards.

Read the safety-related information particularly carefully. Your knowledge can help you recognize dangerous situations and protect yourself and others.

Warning notices

This Operation Manual contains warning notices in several of its sections. A warning notice always warns of imminent danger. It must be understood in conjunction with the situation in which the warning notice is provided. The goal is to avoid accidents and damage.

1.3 Technical Documentation

In addition to this Operation Manual, the technical documentation of the suppliers, including third-party documentation, must be followed.

Third-party documents that contain safety-related information are not repeated in this original Operation Manual. If hazards to the device could arise from supplier components, then this has been addressed in the risk assessment.

 Read the third-party documents

2 Legal provisions

2.1 Directives and standards applied

 See the respective EC Declaration of Conformity

The fundamental rule is that in EU countries, only such products may be marketed for which a declaration has been made that they conform to the provisions of the harmonization directives and the requirements of associated standards.

2.1.1 Evaluation of conformity

As a process for evaluating conformity, an internal production inspection was performed in accordance with the applied harmonization directives.

As a modern, quality-focused company, PSG Germany GmbH is also certified according to EN ISO 9001 (quality management system) and EN ISO 14001 (environmental management system).

Prior to release for shipment, a comprehensive final inspection is performed. The performance data established here is archived and thus is always available.

2.2 Exclusion of Liability

Failure to follow the Operation Manual – particularly the safety instructions – or unauthorized modification of the device or installation of non-original spare parts voids the warranty. The manufacturer assumes no liability for any damages resulting from this or for consequential damages.

The national and European statutory provisions apply.

2.2.1 Modifications

New hazards to the device can arise from modifications. Severe personal injury is possible. After modifications, a re-evaluation of the hazards must be performed. The entire range of the device and all phases of life are to be included.

Only original spare parts may be used for maintenance work, or spare parts that meet the specification of the original spare part. The use of other parts can result in loss of the manufacturer's liability.

3 Safety

3.1 Intended use

The Q-Control control device is used for controlling and regulating membrane pump models QF30Qcon, QF150Qcon, QF1200Qcon, QF2500QCon, and QF4400con.

The device may:

- be used only in the commercial and industrial sector,
- be used only in a building, such as a production facility,
- not be used in an explosion hazard environment.

The Q-Control control device is built in accordance with the state of the art and the accredited safety-related rules and is safe to operate. Faulty operation or misuse, however, bears hazards that can result in personal injury and/or property damage. The device is to be used only for the intended purpose and when in perfect technical condition.

The intended use includes following this Operation Manual and the Operation Manuals of the suppliers, as well as compliance with the suppliers' inspection and maintenance conditions.

The manufacturer is not liable for failure to follow them and any resulting damages. The operator bears the risk.

If faults occur during operation:

- Switch off the device
- Inform technical personnel.

3.1.1 Reasonably anticipated incorrect use

Anticipated incorrect use includes any other use than that described in this Operation Manual.

This includes:

- Operating in an explosion hazard environment.
- Mechanical or electrical bridging of the device or of parts.
- Using other parts than the original parts, or parts outside of the specification of the part being replaced.
- Modifications, changes, and manipulations.
- Use for other pump models than those intended.
- Failure to follow the instructions and specified operating, maintenance, and service conditions.
- Failure to comply with the provisions and regulations in the operator's country, the legal provisions, and accident prevention regulations in conjunction with the device.
- Operating the device outside of the technical data range.

3.2 Safety instructions

This Operation Manual contains fundamental instructions that must be following during installation, operation, and maintenance. Therefore, the installer and the responsible technical personnel/operators must read the Operation Manual prior to installation and commissioning, and it must always be available at the point of use of the device. Follow not only the general safety instructions listed under this main title of Safety, but also the special warning notices inserted in other sections.

Personnel qualification and training

- The personnel for operating, maintaining, inspecting, and installing must have the appropriate qualifications for this work. Trained technicians: Have qualifications that correspond to this function and activity.
- The scope of responsibility, jurisdiction, and monitoring of personnel must be precisely regulated by the operator.
- If the personnel does not have the necessary knowledge, then they must be trained and instructed.
- The operator must ensure that the contents of the Operation Manual have been completely understood by the personnel.

Safety-conscious work

- The safety instructions listed in this Operation Manual, the existing national specifications for accident prevention, and any internal regulations for working, operating, and safety regulations of the operator must be followed.

Hazards if the safety instructions are not followed

Failure to follow safety instructions can result in danger to persons and to the environment. Specifically, failure to follow instructions can result in the following hazards, for example:

- Failure of important functions
- Failure of specified methods for maintenance and repair
- Danger to persons due to electrical, mechanical, and chemical effects
- Danger to the environment due to leakage of hazardous materials

Safety instructions for automated cleaning and sterilization

- Em-tec sensors must not be connected to the system during automated cleaning and sterilization.
- Remove em-tec sensors before automated cleaning or sterilization.

Safety instructions for maintenance, inspection, and installation work

- Fundamentally, work may be performed on the device only when it has been electrically disconnected and secured against unintentional starting. This can be achieved with a lockable E-STOP switch. In addition, a warning sign to prevent switching back on should be applied.
- The operator must ensure that all maintenance, inspection, and installation work is performed by authorized and qualified technicians.

Electrical energy

Depending on the size, the pump is connected to a supply voltage of 115V, 230V, or 400V. Contact with current-carrying parts can cause fatal electrocution (danger).

- Operate the device only at the specified voltage and frequency in order to prevent damage.
- Prior to working on the device, turn off the main disconnect switch and secure it to prevent it from being turned on again.
- Replace damaged cables immediately.
- Lock the electrical enclosure when the work is completed and remove the key.
- When disassembling, disconnect the supply cable at the terminals and remove it.

Overheating

The housing may have a fan on the back side. The fan is designed to make overheating impossible in the interior. If the fan or fan openings are blocked or clogged, then heat can build up. Fire hazard

- Keep the fans and ventilation slits open and clean.
- Keep sufficient distance from adjacent machines or parts of the building.
- Replace defective fan equipment immediately.

Disposal

The device contains components or substances that can endanger the environment if not disposed of properly.

- To prevent environmental damage, do the following: Materials and components:

- Sort materials.



- Do not place components in the trash.
- Dispose in accordance with statutory regulations.
- Have them picked up and recycled by a specialized company.

Electrical equipment

- Check equipment labels regularly in order to prevent the risk of confusion when working with electrical equipment.
- Locate the pump so that it is not directly exposed to moisture (water spray or jets) or heat.

- Operation in a damp or aggressive atmosphere (such as very humid, salty, or acidic atmosphere) can cause increased corrosion.
- To prevent corrosion, avoid contact with corrosive solutions (such as NaCl, HCl) on the outer stainless steel surfaces.

Other warnings and safety instructions

The following instructions warn against improper operation or potential operating errors that can cause damage and endanger the life and limb of the user and other people.

- The maximum permissible delivery pressure depends on the temperature of the medium being transported. Always avoid exceeding the maximum delivery pressure (see warning sign on the pump).

Warning! No liability is assumed for injuries or property damage arising from improper operation, incorrect use, or potential operating errors.

3.2.1 Label on the device

Safety-related information in the form of pictograms and/or labels is provided on the device. They indicate risks that:

- occur frequently, and/or
- have severe consequences.

The following labels are provided on the device:

Meaning	Function	Label
Equipment grounding conductor	Protects persons from electrical shock.	

3.3 Operator

The operator:

...assumes obligations related to operation the device under labor law.

- Operates the device safely and without manipulation through all phases of its life.
- Ensures that personnel read and understand the Operation Manual.
- Instructs the personnel prior to initial use.
- Provides the Operation Manual in paper form at the device.
- Maintains the Operation Manual and third-party documents in legible condition.

...performs organizational tasks.

- Assigns persons to a user group.
- Defines access authorizations to the device, to the control panel, the control system, and the program.
- Instructs the user groups.

...instructs the users in how to act in case of accidents. The content of the instruction includes, for example:

- Locations of first aid stations
 - Location and routing of emergency escape routes
 - How to act in case of emergency, and regular practice of this behavior
- After first aid measures have been taken, seek professional medical treatment immediately.

3.4 Personnel

3.4.1 Description of user groups

Technicians

...are specialists who, on the basis of their career training, professional experience, and recently exercised professional occupation, or personal characteristics are able to perform the technical work on the device. They are assigned and instructed by the operator.

- Have successfully complete an accredited technical training program
- Have knowledge and experience in the use of machinery and equipment
- Are able to evaluate and independently perform the work task
- Have knowledge of the application of applicable standards or the ability to obtain such knowledge
- Have knowledge of the hazards arising in their technical field and knowledge of how to avoid and correct them

...are instructed prior to commissioning the following technicians are required for operation of the device:

- For work on electrical equipment
- For controls and programming
- For setup and testing
- For maintenance and repairs
- For troubleshooting
- For shipping, installation, and disassembly

Operators

...are persons who work with the device in automatic mode

- Can read
- Understand the symbols and instructions on the device
- Can perform the activities independently and in accordance with requirements after being instructed and trained
- Recognize hazards after instruction and can react according to requirements

Ancillary personnel

...are persons who work in the area of the device but are not part of the operating team. This includes, for example, cleaning tasks. Ancillary personnel may not operate the device.

- Can understand instructions
- Can carry out instructions while performing tasks
- Recognize hazards after instruction and can react according to requirements

Trainees

...Are persons who are participating in a technical education program. They may operate the device under the supervision of technicians or perform work tasks in their technical field.

- Can understand instructions
- Can carry out instructions while performing tasks
- Recognize hazards after instruction and can react according to requirements

Third-party personnel

...are external employees who are empowered to act as one of the preceding groups of employees under the following conditions:

- Instructions and safety training by authorized persons must be performed and documented prior to starting work.
- The work by third-party personnel must be coordinated with internal employees to prevent mutual endangerment.
- Prior to starting work, one direct contact person in the form of an internal employee must be defined who is informed of the nature and location of the work being performed.

3.4.2 Limited access

User groups

The user groups may be given access to the device only in accordance with their qualification.

Visitors / Third parties

Third parties are fundamentally not allowed access to the factory facility without supervision. When accompanied by a suitably qualified person who assumes responsibility for the visitors, access to the facility is allowed. The following differentiation must be made:

- Visitors who enter areas of the facility that have low hazard potential (administration and receiving) can do so when accompanied by the responsible person.
- Visitors who enter areas of the facility that have higher hazard potential (near production equipment) must receive instruction and safety training from suitably qualified persons. This must be documented in writing.

Age

Users of the device must be 18 years old. Trainees under 18 years of age may operate the device only in the presence of a trainer for training purposes.

Health

The device may not be operated by persons who are under the influence of substances that increase reaction time or who are not able to operate it for health reasons.

Users must be able to recognize optical and acoustic hazard signals.

→ Keep unauthorized persons away from the device.

4 Transport, storage, installation, decommissioning, disposal, recommissioning

4.1 Transport

The pump with Q-Control is packaged in a protective carton and/or on a pallet as a standard and can thus be transported using typical industrial trucks and lifting gear with slings.

The center of gravity is not necessarily in the middle.

4.2 Storage

In general, the pump with Q-Control is ready for use when shipped. If it is not placed into service immediately, then serviceable storage conditions are important for subsequent trouble-free operation.

Protect the control device against wet, cold, contamination, UV radiation, and mechanical impacts.

The following storage conditions are recommended:

- Consistently ventilated storage space free of dust and vibration
- Avoid direct sources of heat (sunlight, heaters)
- Do not tip, slide, drop, or fall down

If the storage conditions are not met, components can corrode or age prematurely. The service life of the device will be reduced.

During storage, unforeseen events can occur. Damage can occur to the device or components of the device.

- Check the location, packaging, and general condition of the stored components at regular intervals.

4.3 Assembly

The Q-Control module is shipped fully assembled. No further assembly is required.

Once the packaging is removed, check the device for:

- Damage
- Completeness
- Cleanliness
- Correctness (all screws installed and seated, connections, etc.)
- Installation site
- Level, stable foundation

4.4 Decommissioning

When decommissioned, functionality of the device is interrupted for an indeterminate period of time.

→ The following measures are necessary:

- Switch off and disconnected all sources of energy.
- Prevent unauthorized persons from restoring energy sources.
- Perform regular visual inspections.

4.5 Disposal

The device contains components or substances that can endanger the environment if not disposed of properly.

4.5.1 Note on battery disposal

In connection with the sale of batteries, we are obliged as a dealer under the Battery Act to inform about related regulations and obligations.

The chemical contents of batteries can damage the environment and health if not stored and disposed of properly. Only by collecting and recycling batteries separately from other household waste can harmful effects on health and the environment be avoided. Batteries may also contain recyclable raw materials. They must therefore not be disposed of with normal household waste.

As the end user, you are legally obligated to return or properly dispose of used ones. For this purpose, you can hand in your used batteries at the public collection points or at sales outlets free of charge. You can also return your used batteries to us. The return of the batteries to us must be sufficiently stamped in any case:

PSG Germany GmbH
Hochstraße 150-152
47228 Duisburg, Germany

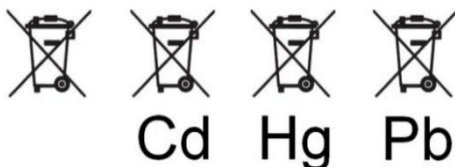

Batteries containing harmful substances are marked with the symbol of a crossed-out garbage can, similar to the symbol in the illustration. Below the garbage can symbol is the chemical name of the pollutant.

Pb: Battery contains lead

Cd: Battery contains cadmium

Hg: Battery contains mercury

These products must not be disposed of in household waste.



4.6 Recommissioning

When recommissioned, functionality of the device is restored after a longer period of disuse.

→ Proceed as described in the “Commissioning” section.

5 Installation

The time of commissioning is the point at which a product reaches its intended use. Commissioning is done in accordance with this manual and is the responsibility of the operator.

-  Follow intended use and observe the technical data.
-  Follow the information in third-party documents.
-  Safety instruction from chapter 3 have to be followed for commissioning of this product.

5.1 Electrical connection

The pump with Q-Control has a power cable with or without a plug. All electrical and control connections must be made while the device is deenergized. Only technicians may replace power cables and plugs, in order to prevent hazards. The grid voltage must match the values given in the technical data. The person responsible for installation must ensure that the electrical connection is grounded and in accordance with standards. If the power supply is not appropriately grounded, then the pump must be grounded additionally at the point provided. A 24VDC power supply is integrated in the pump with Q-Control and provides power to the controller and the ports. The controller must never be connected or disconnected while under load.

5.2 Digital inputs

All digital inputs can be connected to a potential-free contact between the digital input and ground. In such cases, the inputs will be pulled up internally and the switching logic will be inverted internally (closed switch is 0, open switch is 1). This switching logic can be reversed in the configuration menu "DIN inverted". Alternatively, a source of up to 5 V DC can be connected to the digital input, because the inputs can be pulled up internally by 10k. Because this inverts the logic (closed switch is 0, open switch is 1) there is a configuration option to reverse this.

5.3 Analog inputs

The first three analog inputs are configured for current measurement, and the fourth analog input for voltage measurement. All channels are scanned at a resolution of 16 bits.

Ground connections for all channels are internally connected. The grounds for analog and digital inputs are internally connected.

5.4 Analog output

There are two 16-bit output channels, one control output for the pump and one monitor output.

The monitor output (2) can be set for 4-20 mA current.

This output can be used by the user (see section 12.6.1).

The control output channel (1) can be configured as a current (4-20 mA fixed or 4-20 mA freely configurable), voltage (0-5V, 0-10V fixed or 0-10V freely configurable) or as a pulsed output. This output is configured by the manufacturer and cannot be modified by the user.

5.5 Digital output

The digital output is programmed as ready to run for all pumps with Q-Control. See Section 12.6.2 for more information.

5.6 Battery

The internal real-time clock is fed by a CR1220 button cell battery. It must be replaced approximately every 5 years. Changing the battery is described under maintenance/repairs see section 6.3.1.

5.7 USB

The USB interface is OTG capable and can be used for connecting an external USB flash drive (USB stick). The USB interface can be used for data logging (section 13), for loading / saving the configuration (section 14) and for firmware updates (section 15).

5.8 Signal connections and wiring

5.8.1 Type and pin-allocation

All ports are designed with the same connection type:

M12, female (socket), 8-pin

Pin-allocation:

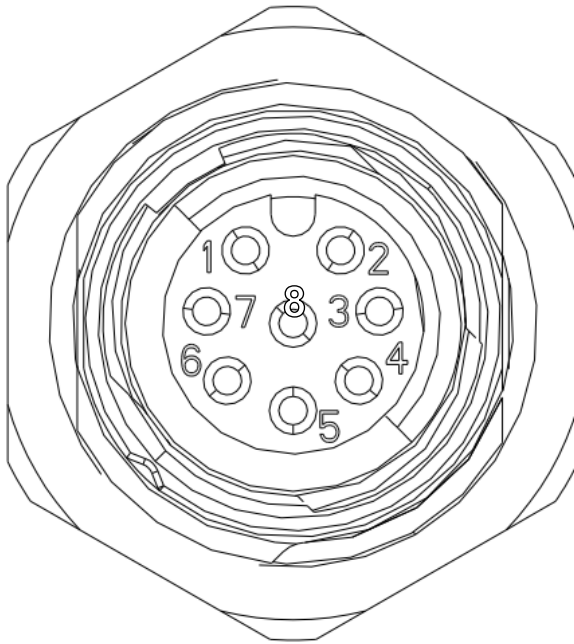

Picture 1 Connection jack pin-allocation

Each connection is delivered with a suitable mating connector (M12, 8-pin, male). The user can use this connector to wire own sensor and signals with the Q-Control Pump.

NOTE

The pin assignment of the mating connector is mirror-inverted to the pin assignment of the socket on the Q-Control.

For more information and technical specification see section 18.

5.8.2 Port X1

PIN	Function	Comment
1	24V+	Power supply
2	0V	Power supply
3	DI 3	Digital input 3
4	DI 2	Digital input 2
5	DI 1	Digital input 1
6	-	-
7	DO	Digital output
8	-	-

Table 1 Allocation Port X1

Connection example:

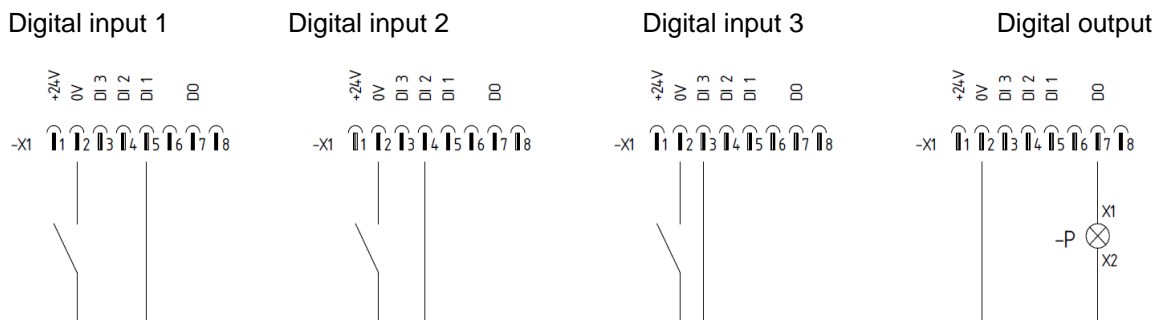

Picture 2 Connection example, Port X1

Diaphragm monitoring

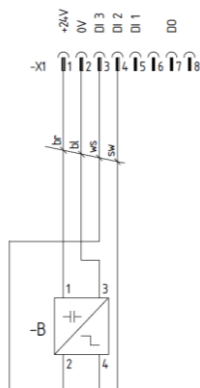

Picture 3 Connection example, Diaphragm monitoring, Port X1

For further information on the use of the supplied sensors or a membrane monitoring, see Chapter 9.

5.8.3 Port X2

Pump types based on pump coded (item numbers):

- QCON Standard
- QCON...-EP with integrated em-tec and PendoTECH Option
- QCON...-E with integrated em-tec Option
- QCON...-P with integrated PendoTECH Option

Function				
PIN	QCON	QCON...-EP	QCON...-E	QCON...-P
1	24 V+ power supply			
2	0 V power supply			
3	AI 1+	-	AI 2+	AI 4+
4	AI 1-	-	AI 2-	AI 4-
5	AI 3+			
6	AI 3-			
7	-	AO +		
8	-	AO -		

Table 2 Port X2 allocation

AI: Analog-Input

AO: Analog-Output

5.8.4 Port X3

Q-Control Standard

	Function	Comment
PIN	QCON	QCON
1	24V+	Power Supply
2	0V	Power Supply
3	AI 2+	Analog Input 2+
4	AI 2-	Analog Input 2-
5	AI 4+	Analog Input 4+
6	AI 4-	Analog Input 4-
7	AO +	Analog Output +
8	AO -	Analog Output -

Table 3 Allocation Port X3

Connection Example:

Analog Input 1
4-20 mA

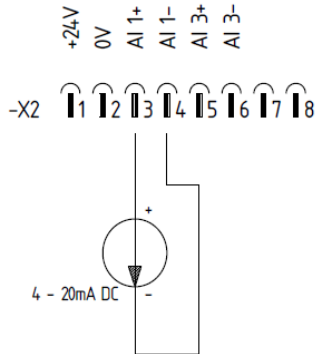

Analog Input 3
4-20 mA

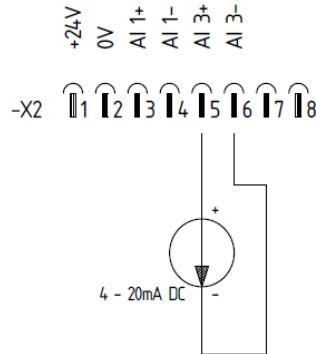

Pressure Sensor
Labom Pascal CS2110 (analog)

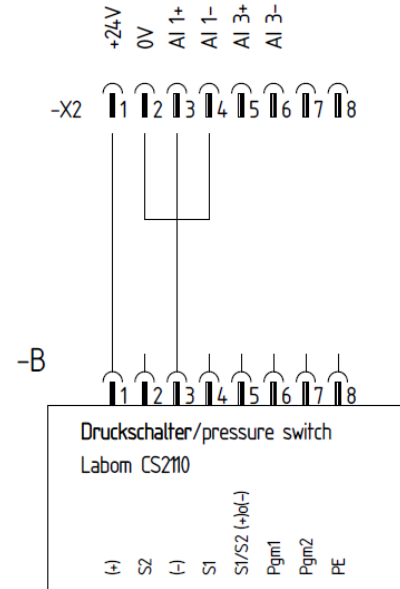

Analog Input 2
4-20 mA

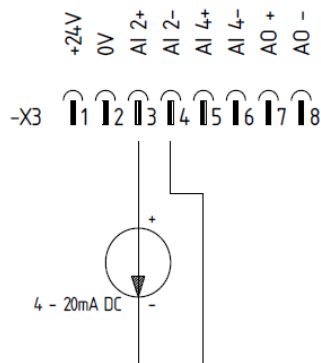

Analog Input 4
0-10 VDC

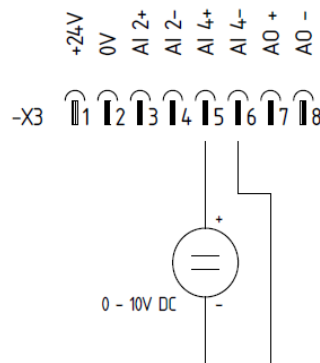

Analog Output
4-20 mA

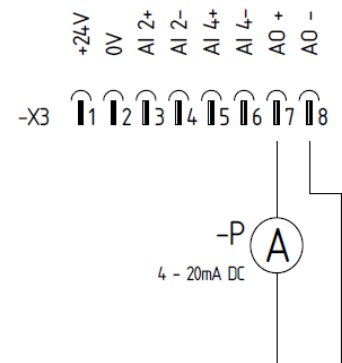

Picture 4 Connection Example, Port X2 / X3

For further information on the use of the supplied sensors or a diaphragm monitoring, see chapter 9.

With integrated em-tec option (item no.: QCON...-EP and QCON...E)

Only with integrated em-tec signal processor QCON...-EP und QCON...-E

The em-tec sensors connects to port X3 in the product variants QCON...-EP und QCON...-E The em-tec sensors are delivered with a standardized plug, which directly connects to the port.

5.8.5 Port X4

Only with integrated Option PendoTECH (Item no.: QCON...-EP + QF...QCON...-P)

The PendoTECH sensor connects to port X4 with the included extension cable.

PIN	Function
1	Signal +
2	-
3	Signal -
4	-
5	Silver
6	Excitation -
7	-
8	Excitation +

Table 4 Port X4 / Sensor connection PendoTECH

5.8.6 Port X5

Only with integrated Option em-tec (Item no.: QCON...-EP und QCON...-E)

Port X5 is used to connect to the integrated em-tec FlowMCP-a. The interface can be used for communication and for calling up the web interface. The connection is made via a conventional RJ-45 network interface (LAN cable).

5.8.7 Port RS485

PIN	Function
1	GND
2	Y
3	Z
4	B
5	A
6	-
7	-
8	-

Table 5 Allocation Port RS485

6 Maintenance

6.1 Warning notices

Regular maintenance and care reduce the risk of potential interruptions in operation and help to extend the service life of your device.

We are not liable for damage arising from incorrect repair attempts. Damage due to incorrect repair attempts will void all warranty claims.

If a pump is not used for a longer period of time, devices and piping should be completely emptied.

- **Danger**

Warning; Electricity!



→ When maintenance and inspection work is to be done, the equipment must be shut down, for example by unplugging the power cable or using a repair switch, and secured to prevent switching on unintentionally. If not disconnected from the power grid, there is a danger of electrical shock or of the pump starting unintentionally. In addition, a warning sign to prevent switching back on should be applied.

6.2 Inspections

→ Inspect regularly:

- The equipment grounding conductor system
- The grounds
- The housing
- The labels on the control elements

→ Check the information in the Commissioning section.

6.2.1 Check safety equipment regularly

Protection devices are conceived so as to reduce the risk of injury to a residual risk when used as intended. If protection devices are not functional, severe injury can occur.

- Do not manipulate or modify protection devices.
- Always operate device with functioning protection devices.
- Remove protection devices only when the main disconnect switch has been switched off and secured against switching on again.
- Install the protection devices again after repairs are complete and check their functionality.

6.3 Maintenance

6.3.1 Changing the battery

The integrated button cell must be replaced approx. Every 5 years. The configuration remains in the flash memory of the Q-CONTROL, even if the button cell is removed.

The time and date must be adjusted after the change.

The button cell is installed on the back of the Q-CONTROL control unit. In order to reach the button cell, the drive unit of the pump must be opened.

To change the button cell, the following steps must be carried out.

	QF30	QF150	QF1200	QF2500	QF4400 QF5K
Remove feed chamber	X	X			
Remove ring drive	X	X	X		
Remove housing screws	X	X	X	X	X
Remove housing cover and set aside	X	X	X	X	X
Remove cable connections	X	X	X		
Remove nuts from QCON panel (SW6)	X	X	X	X	X
Remove panel cover	X	X	X	X	X
Replace battery	X	X	X	X	X
Reassemble pump	X	X	X	X	X
The above mentioned steps have to be carried out in reverse order to assemble the pump again.	X	X	X	X	X

Table 6 Work step for changing the battery

NOTE

Please observe the main instructions for the respective Quattroflow pump before opening the pump to change the button cell.

The work should only be carried out by trained personnel!

6.4 Errors and trouble shooting

In the event of malfunctions, first check whether there is an operating error or another cause that cannot be attributed to a defect in the device - such as a power failure.

As soon as an (error) message appears in a particular operating mode or if a particular parameter is changed, read the associated section in this Operation Manual. Additional information on potential root causes can be found there.

The following table lists the most important messages. In the given chapter further information and solutions can be found.

Message / Popup	Section
Analog Alarm ... (Main window)	11.1.1 Process Alarms for analog
Digital Alarm ... (Main window)	11.1.2 Process alarms digital 11.2.1 Sensor-Alarm analog inputs
Error analog-output (Main window)	12.6.1 Analog output (AO)
Keylock for external Start/Stop is active (Main window)	12.5.2 Function of External start/stop in all operating modes
Input signal is too low. Check signal (Main window)	11.2.1 Sensor-Alarm analog inputs
Input signal is too high. Check signal (Main window)	11.2.1 Sensor-Alarm analog inputs
Check dispense settings (Settings > Dispensing)	10.4.2 Configuration
Dispense settings reset (Settings > Parameter 1 > Cal / Slope)	12.2.3 Influence of the calibration factor on the dispensing operating mode
Incorrect setting(s) (Settings > Sensor mapping)	8.1.2 Assign sensor as master sensor for the operating modes
Incorrect setting(s) (Settings > External control)	10.3.2 Configuration
Incorrect setting(s) (Settings > Analog input 1...4 > Type)	8.1.1 Basic configuration of the analog input
No flow sensor set (Settings > PID Flow control > Autotune)	10.5.2 PID values and Autotune
No pressure sensor set (Settings > PID Pressure control > Autotune)	10.5.2 PID values and Autotune

Message / Popup	Section
QControlConfig.bin wrong version (Settings > Configuration > load)	14.3 Compatibility of the configuration
Sensor Alarm AINx Input value is too low / too high. Check signal (Main window)	11.2 Sensor alarms and sensor monitoring
Specific sensor alarms for integrated option em-tec	9.1.8 Errors, trouble shooting
Specific sensor alarms for integrated option PendoTECH	9.2.7 Errors and troubleshooting
PID error check Check sensor position (Main windows mode flow- and pressure control)	10.5.5 PID Error for Options em-tec / PendoTECH

Table 7 Troubleshooting; Messages

6.5 RMA process

If you have purchased the pump from a Quattroflow distributor, please contact your distributor. They will help you along with the process.

If a pump is to be sent to a Quattroflow location in Germany for inspection or repair, please contact the service team at PSG Germany / Quattroflow. You will receive an RMA number and additional information on how to proceed.

NOTE

Please do not send a pump to the Quattroflow plant without first contacting the manufacturer. This will slow down the RMA process and the return cannot be processed.

If a pump is to be sent to the Quattroflow plant in Germany, the following documents are required:

- Incident Report (error description, contact data, pump data)
- Decontamination certification (only if a feed chamber is included in the return)

Forms are available upon request from the Quattroflow team.

For distributors, the documents are available for download in the Quattroflow portal:

<https://portal.psgdover.com/>

7 General operation and menu structure

All Quattroflow pump models that are shipped with Q-Control have a main switch installed, to switch the power to the pump on or off. When the main switch is pressed, the Q-Control display switches on automatically.

Please note that for all Quattroflow pumps with Q-Control, the main switch must be pressed and held briefly. Depending on the pump, it may take a few seconds for the pump to be switched on or off completely. The main switch must not be pressed several times in rapid succession and must not be held down for a long time.

7.1 Display and softkeys

The front control panel of the Q-Control with display has four softkeys that can have context-dependent functions, which can vary depending on the current display screen. The function of each button is shown on the display above or next to the button.

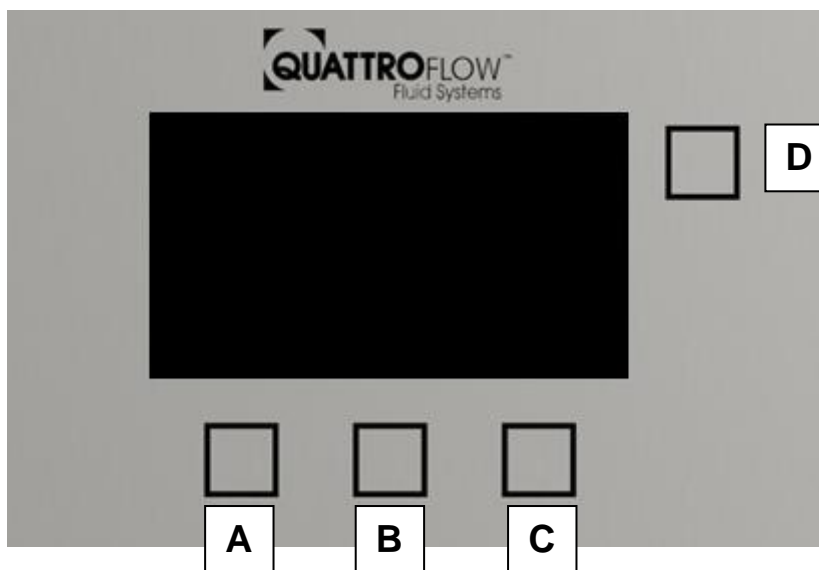

Picture 5 Q-Control Panel with Softkeys

Key-binding in main windows / operation mode

Key	Display	Function
A C	- +	Increase or decrease values in different operation modes
B	START STOP	Start pump Stop pump
D	MENU	When pump is stopped Open menu / selection for operation mode
	-	When pump is running Hold key to see current analog input values Key is not labeled on display See chapter 12.8 for more information

Table 8 Function and description of the softkeys; part 1

Key-binding in menu / settings

Key	Display	Function
A C	↑ ↓	Vertical scrolling
	← →	Horizontal scrolling
B	SELECT	Select first line on current tab
	NEXT	Go to next line on current tab
	SAVE	Save all values on current tab
	OK	Start or confirm procedure
D	-	BACK to previous menu page / main screen Key is not labeled on display

Table 9 Function and description of the softkeys; part 2

The above table shows only the most important functions of the four softkeys. Other assignments and other functions are described in the associated sections of this Operation Manual.

7.2 Navigation

7.2.1 Main window

The main window is displayed when the pump is switched on.

At the top left, in the header, it shows the currently selected operating mode. Further information about each operating mode can be found in section 10.

7.2.2 Selecting the operating mode

Select the operating mode from the **Operating mode** selection window:

MENÜ > ↓ ↑ > **Operating mode** > **SELECT**

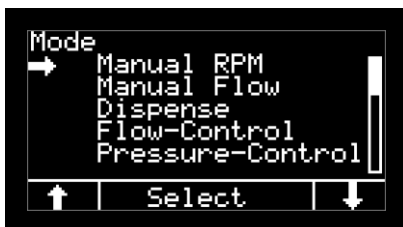

Picture 6 Mode selection (exemplary)

NOTE

Please note that the selection list for operating modes is adapted dynamically to the configuration in the settings. For more information, see Table 28.

7.2.3 Settings (configuration)

To get to the settings (configuration), proceed as follows:

MENÜ > ↓ ↑ > **Settings** > **SELECT**

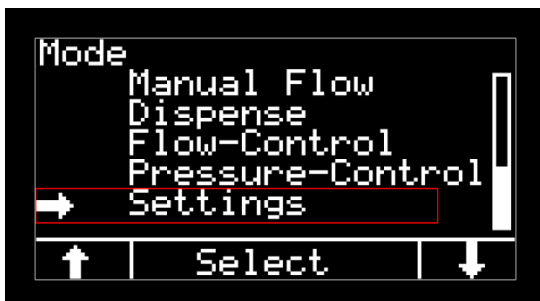

Picture 7 Open the settings (configuration)

Use the buttons ← → to navigate through the various tabs.

When the **SELECT** button is pressed, the parameter in the first line is selected and the current setting flashes slowly.

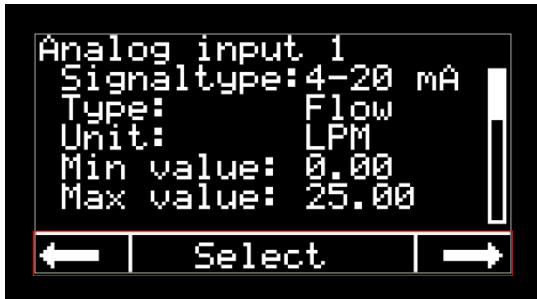

Picture 8 Navigation in the settings (example)

To change the value, press the buttons \leftarrow \rightarrow or - + (depending on the type of parameter).

To apply the value setting, press the **NEXT** button.

The next line is then selected and its parameter flashes slowly.

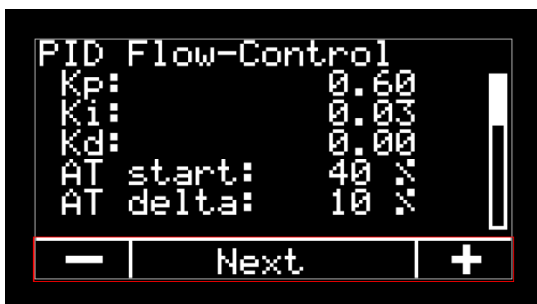

Picture 9 Choose next parameter / next line (example)

To save the changes, press **NEXT** several times until the bottom line and the bottom parameter have been selected.

The **SAVE** button is now displayed. Press the **SAVE** button and all changes in the current tab will be applied.

While the parameters are flashing, the **BACK** button (top right) can be used to cancel the action, and the parameters that have already been changed will be reset to their previous values.

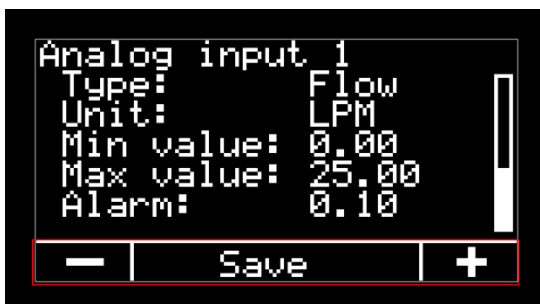

Picture 10 Save changes (example)

7.3 User levels, login, and PIN

The settings (configuration) are divided into two user levels:

- Open settings, without any PIN
- Settings at the Supervisor level with PIN code

A PIN code is required to pull up the tabs in the Supervisor level. The settings and parameters have a fundamental influence on the function of the pump and the Q-Control, and should only be modified by persons who are familiar with the function of the parameters.

Enter the PIN code from the **Login** tab:



Picture 11 Login (PIN)

The following Supervisor PIN is preset at the factory:

0 0 0 0 0

If the PIN code has been entered correctly, the text on the middle button changes from **SELECT** to **LOGOUT** and the PIN is shown as * * * * *.

The **LOGOUT** button exits the Supervisor level and the PIN code must be entered to gain access again.

If the pump has been switched off at the main switch (power off), LOGOUT occurs automatically.

Once the PIN code has been entered correctly, and the Supervisor level has been enabled, the user can assign a new PIN code in the **Parameter 2** tab.

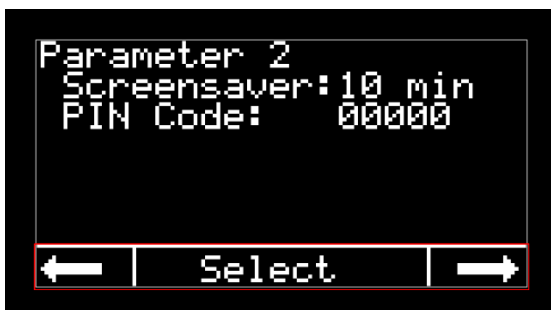

Picture 12 Settings, Parameter 2 (example)

7.1 Menu structure and brief description of settings

The following picture and table shows the sequence of individual tabs that can be found within the settings. The tabs, which can be scrolled through from left to right in Q-Control, are shown from top to bottom in this table.

The individual parameters and a brief functional description are also listed. Further information on parameters and standard values can be found in section 18.2.

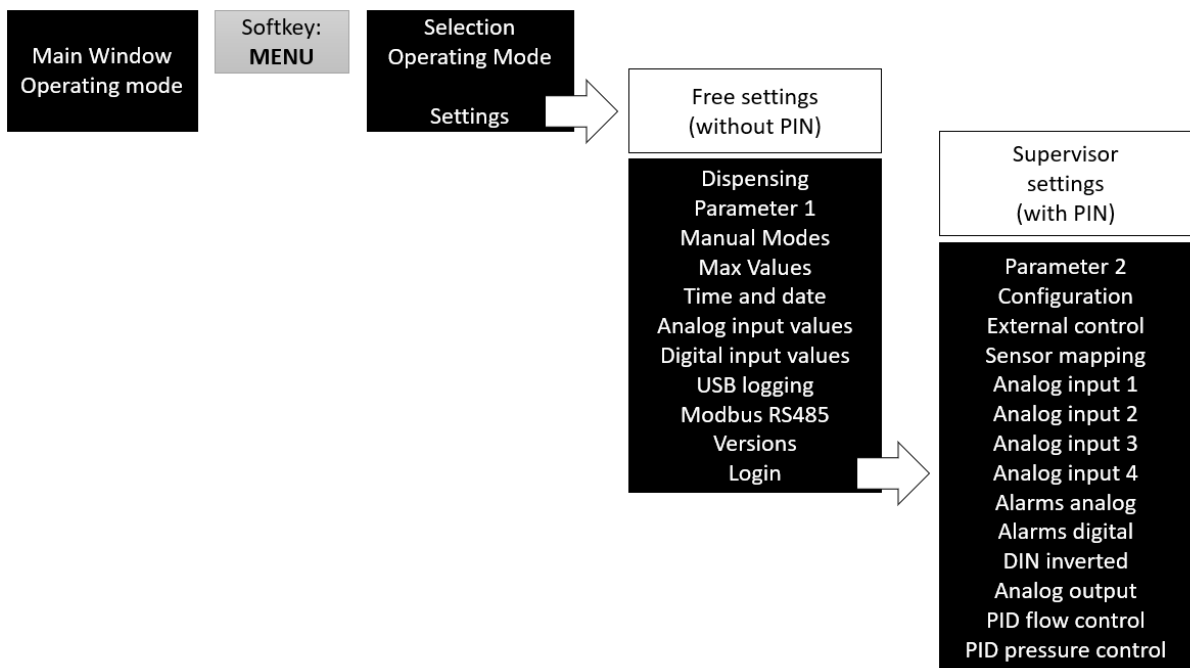

Picture 13 Operating and menu structure

Tab	Parameter	Unit	Values	Brief description
Open settings without entering a PIN code				
Dispense	Unit		ml, l, gal	Unit for dispensing volume
	Volume		numeric value	Dispensed volume
	Number of cycles		numeric value	Number of cycles for dispensing
	Run	s	numeric value	Running time in which the volume is to be reached.
	Wait	s	numeric value	Waiting time between dispensing cycles
Parameter 1	Language		German, English, Chinese	Select the language for Q-Control
	Unit F		mlPM, LPM, LPH, GPM	Main unit for flow rate Shows the main unit for all operating modes
	Unit P		bar, PSI	Main unit for pressure Shows the main unit for all operating modes
	Cal	ml/rev	numeric value	Calibration factor or displacement volume rev = revolution
	Slope	%/s		Positive and negative motor acceleration
Manual modes	Totalizer		Yes, No	Activates and sets settings for the totalizer function
	Input		Intern, Sensor, Internal, Sensor	Input source for totalizer. Internal calculation or flow rate sensor
	Reset		Ok?	Resets the totalizer
Max values	Max RPM	RPM	numeric value	Maximum motor speed
	Max F	Dyna-mic	numeric value	Maximum flow rate In the unit from <i>Parameter 1 > Unit F</i>
	Max P	Dyna-mic	numeric value	Maximum pressure In the unit from <i>Parameter 1 > Unit P</i>
Time and date	Hour		0 ... 23	Settings for time and date. Used only for USB data logging and screensaver.
	Minute		0 ... 59	
	Day		1 ... 31	
	Month		1 ... 12	
	Year		2020 ...	
Analog input values	Analog 1	mA		Displays the current values of the analog inputs.
	Analog 2	mA		
	Analog 3	mA		
	Analog 4	V		
Digital input values	Digital 1			

Tab	Parameter	Unit	Values	Brief description
	Digital 2			Displays the current values of the digital inputs.
	Digital 3			
USB Logging	Active		On, Off	Activates USB logging
	Decimal		. ,	Selects the decimal point for USB logging
	Interval	s	numeric value	Interval for data logging
Modbus RS485	Protocol		RTU, ASCII	Settings for external controls and data logging via RS485
	Address		1 ... 255	
	Baudrate		9600, 19200, 38400, 115200	
	Parity		None, even, odd	
Versions	Hardware Bootloader Software Ser. no. Q-Con			Displays versions
Login	PIN Logout			Login Supervisor Level Logout Supervisor Level
Supervisor settings with PIN code				
Parameter 2	Screensaver	Minute	1 ... 600	Waiting time for screensaver
	PIN Code		00000 ... 99999	PIN code for Supervisor level
Configuration	USB Write		Ok?	Save the configuration to USB stick
	USB Load		Ok?	Load the configuration from the USB stick
	Factory reset		Ok?	Loading the factory settings (delivery status)
External control	External RPM		AIN1, AIN2, AIN3, AIN4, Off	Select signal source for speed control via external signal
	Start/Stop		AIN1, AIN2, AIN3, AIN4, DIN1, DIN2, DIN3, Off	Select signal source for start/stop via external signal
	Threshold	mA V	AIN1,2,3: 4...20 AIN4: 0...10	Threshold value for start/stop via analog input
	Ext Trigger		Yes, No	Only for external start/stop
	Keylock		On, Off	Only for external start/stop
Sensor mapping	Flow		AIN1, AIN2, AIN3, AIN4, Off	Master sensor for flow
	Pressure		AIN1, AIN2, AIN3, AIN4, Off	Master sensor for pressure

Tab	Parameter	Unit	Values	Brief description
Analog input 1	Signal type		4-20 mA	Configuration of the analog input. The signal type is preset
	Type		Raw, Flow, Pressure, emtec, P-TECH	Set according to sensor
	Unit		mIPM, LPM, LPH, GPM bar, PSI	Unit of type Set according to sensor
	Min value		numeric value	Measurement value of the analog signal at 4 mA In the unit from the <i>unit</i> parameter
	Max value		numeric value	Measurement value of the analog signal at 20 mA In the unit from the <i>unit</i> parameter
	Alarm		numeric value	Defining an alarm value In the unit from the <i>unit</i> parameter
Analog input 2	Signal type		4-20 mA	Configuration of the analog input. The signal type is preset
	Type		Raw, Flow, Pressure, emtec, P-TECH	Set according to sensor
	Unit		mIPM, LPM, LPH, GPM bar, PSI	Unit of type Set according to sensor
	Min value		numeric value	Measurement value of the analog signal at 4 mA In the unit from the <i>unit</i> parameter
	Max value		numeric value	Measurement value of the analog signal at 20 mA In the unit from the <i>unit</i> parameter
	Alarm		numeric value	Defining an alarm value In the unit from the <i>unit</i> parameter
Analog input 3	Signal type		4-20 mA	Configuration of the analog input. The signal type is preset
	Type		Raw, Flow, Pressure, emtec, P-TECH	Set according to sensor
	Unit		mIPM, LPM, LPH, GPM bar, PSI	Unit of type Set according to sensor
	Min value		numeric value	Measurement value of the analog signal at 4 mA In the unit from the <i>unit</i> parameter
	Max value		numeric value	Measurement value of the analog signal at 20 mA In the unit from the <i>unit</i> parameter
	Alarm		numeric value	Defining an alarm value In the unit from the <i>unit</i> parameter
Analog input 4	Signal type		0-10 V	Configuration of the analog input. The signal type is preset
	Type		Raw, Flow, Pressure, RSS	Set according to sensor

Tab	Parameter	Unit	Values	Brief description
	Unit		mIPM, LPM, LPH, GPM, bar, PSI	Unit of type Set according to sensor
	Min value		numeric value	Measurement value of the analog signal at 0V In the unit from the <i>unit</i> parameter
	Max value		numeric value	Measurement value of the analog signal at 10V In the unit from the <i>unit</i> parameter
	Alarm		numeric value	Defining an alarm value In the unit from the <i>unit</i> parameter
Alarms analog	Analog 1		On, Off	Activate and deactivate analog alarms
	Analog 2		On, Off	
	Analog 3		On, Off	
	Analog 4		On, Off	
Alarms digital	Digital 1		On, Off	Activate and deactivate digital alarms
	Digital 2		On, Off	
	Digital 3		On, Off	
DIN inverted	Digital 1		On, Off	Invert logic of the digital signal
	Digital 2		On, Off	
	Digital 3		On, Off	
Analog output	Type		Off, 4-20 mA	Activate the analog output Motor speed feedback
PID Flow control	Kp		numeric value	Parameters for the controller
	Ki		numeric value	Parameters for the controller
	Kd		numeric value	Parameters for the controller
	AT Start	%	0 - 100	Starting value for autotune
	AT Delta	%	0 - 100	Delta value for autotune AT Delta \geq AT Start
	Autotune		Ok?	Execute autotune
PID pressure control				See PID flow control

Table 10 Menu structure and parameter

8 Usage of analog and digital sensors

8.1 Using sensors with analog signal

Q-Control has a total of four analog inputs, and one sensor can be connected to each. Please note that the input signal of the analog input matches the output signal of the sensor.

The sensor can be used as a master sensor for the operating modes (e.g., flow or pressure control, displaying the sensor values in the *Manual RPM* mode. At the same time, an alarm can be assigned to the sensor.

Altogether, Q-Control can work with one master sensor each for flow and pressure.

Alternatively, one sensor with an analog signal can be used only in the background, for example as a pressure monitor.

8.1.1 Basic configuration of the analog input

The analog input must be configured for the corresponding sensor. The values to be set can be found in the data sheet or rating plate of the sensor. Note the particular configuration of the sensor.

The configuration is set in the following menu:

MENU > Settings > Analog input 1...4

Parameter	Description
Signal type	Set permanently, depending on the analog input. Analog input 1, 2, 3: 4-20 mA Analog input 4: 0-10 V
Type	Setting the type for the measured value Raw value Flow Pressure em-tec (analog input 1, 2, 3) PendoTECH (analog input 1, 2, 3) RSS (analog input 3, 4)
Unit	Flow: mlPM, LPM, LPH, GPM Pressure: bar, PSI
Min value	Measurement value of the analog signal at 4 mA (or 0 V with analog input 4) In the unit from the Unit parameter
Max value	Measurement value of the analog signal at 20 mA (or 10 V with analog input 4) In the unit from the Unit parameter
Alarm	Setting the alarm value. In the unit from the Unit parameter adjustable up to the value of parameter Max value

Table 11 Configuration analog-input

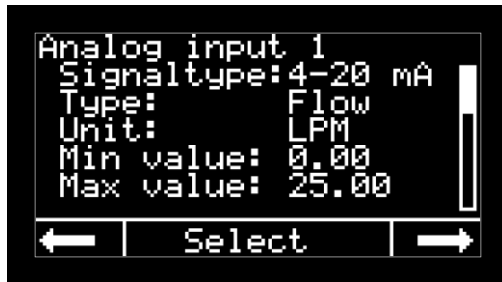

Picture 14 Analog input; configuration, part 1 (example)

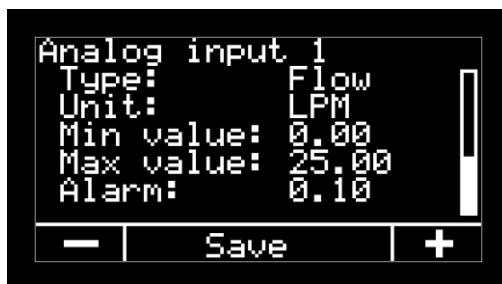

Picture 15 Analog input; configuration, part 2 (example)

NOTE

Not all sensors are scaled from 0 to the maximum measured value, and for many sensors, the scaling of the analog signal is adjustable. Please ensure that the sensor scaling matches the parameters **Min value** and **Max value**.

The following conditions apply to the selection of the type:

The type of analog signal (flow, pressure) must match the assignment of the sensors in the settings **sensor mapping**.

Otherwise, the following error message is displayed when selecting the type:



Picture 16 Error message Analog input

In this case set the value for the respective analog-input to **Off** on page **sensor mapping**. Now the type can be freely assigned in the settings of the analog input.

Once this configuration has been done, the sensor can be used for analog alarms. For more information, see section 11 Alarms.

8.1.2 Assign sensor as master sensor for the operating modes

If the sensor is to be used for the operating modes (e.g., flow or pressure control, displaying sensor values in the *Manual RPM* mode), then the sensor must be assigned as a master sensor.

Use the following parameters to assign the sensors:

MENU > Setting > Sensor mapping > Flow

MENU > Setting > Sensor mapping > Pressure

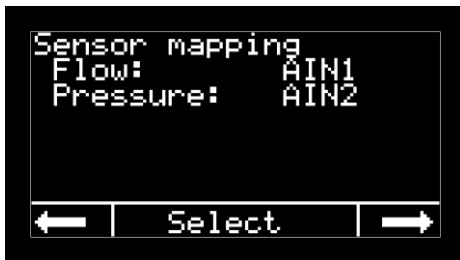

Picture 17 Sensor mapping (example)

The following conditions apply for the assignment:

- Only one analog input (AIN1, AIN2, AIN3, AIN4) can be assigned to each type (flow or pressure)
- The sensor type (flow or pressure) must match the **Type** in the **Analog input**
- An analog input cannot be assigned twice
- The analog input may not be assigned to the function **External RPM**
- The analog input may not be assigned to the function **External start/stop**

If one of the above conditions is not met, then the following error message is displayed:

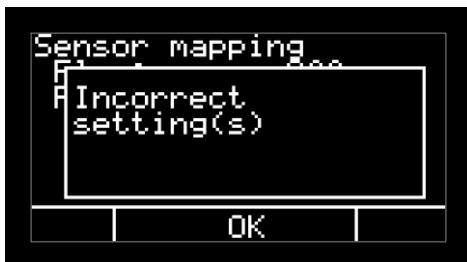

Picture 18 Sensor mapping; Error message incorrect settings

Adjust the assignment to the sensors to suit the conditions listed above.

The following sequence is recommended when setting up the sensors:

1. First, perform the basic configuration of the sensors according to section 8.1.1.
2. Then assign the sensor as a master sensor.

8.2 Using sensors with a digital signal

Q-Control has a total of three digital inputs, and one sensor can be connected to each. Digital sensors, unlike analog sensors, cannot be used for transmitting dynamic process data. For this reason, digital sensors cannot be used as master sensors.

Sensors with a digital switch signal can typically be used for the following applications:

- Use for various process alarms
- Diaphragm monitoring
- Pressure monitoring
- Flow monitoring
- Pump start/stop from an external controller

The switch state and the logic of digital sensors is continuously monitored by Q-Control in the background. To set up an alarm for a digital sensor, follow the instructions in section 11.

The logic of each digital input can be set in the following settings:

MENU > Settings > DIN inverted



Picture 19 Settings DIN inverted (example)

9 Use of the integrated signal processing for em-tec flow sensors and PendoTECH pressure sensors and other special sensors (optional)

Q-Control pumps in Single-Use design are optionally equipped with integrated signal processing for em-tec clamp on flow sensors and/or PendoTECH pressure sensors. The sensors directly connect to the terminal on the back of the pump. After a quick software parameterization, the measurement system is ready to use. To ensure maximum precision, the analog inputs are calibrated from the factory.

The following sections describe the installation and use of the em-tec and PendoTECH measurement systems.

Pumps with this option are delivered with Firmware-Version 02.XX.XX (or newer)

The following chapters describe the use of various options that are offered by Quattroflow and can be used in combination with Q-Control pumps.

9.1 Integrated signal processing for em-tec clamp on flow sensors – Only for SU Pumps with code QCON...-E and QCON...-EP with Firmware 02.XX.XX

9.1.1 General information

In cooperation with em-tec, Quattroflow offers clamp on flow sensors for use with Quattroflow pumps. The respective sensor type depends on the pump size and the type and size of the hose. Please note that the em-tec sensors must be calibrated to the corresponding hose and to the application. For more information, please contact the Quattroflow team.

For the direct connection of an em-tec flow sensor, the Q-Control pump is available with the integrated em-tec FlowMCP-a signal processing unit. This unit is internally powered by a 24 VDC power supply and does not require a separate power supply.

The raw signal of the sensor is processed and passed on to the Q-Control controller as a 4-20 mA analog signal. Thus, the sensor can be used like any conventional sensor with all functions of the Q-Control pump (for example, flow control and data recording). Furthermore, the FlowMCP-a has a web interface, that the user can use to make various settings.

In addition to the flow rate, the Q-Control soft- and hardware also evaluate the RSS value (Received Signal Strengths), which shows the signal quality and the accuracy of the measurement.

The pump with integrated em-tec transmitter has an additional push button at the front side for zeroing. It is marked with **ZERO FLOW SENSOR**.

9.1.2 Connection to the pump

The flow signal is connected to analog input 1 (AIN1) and the the RSS signal to analog input 4 (AIN4). This configuration cannot be changed by the user. Analog inputs 1 and 4 are internally wired and can therefore not be used for additional sensors.

The em-tec sensor connects to the corresponding socket at the back of the pump.

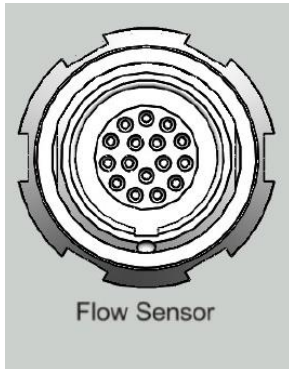

Picture 20 em-tec connection socket

Further information on the assignment and use of the connections can be found in Chapter 18.1.2.

NOTE

When connecting the plug, care must be taken to ensure that the plug and socket are correctly aligned. The correct alignment is marked with a red dot.

9.1.3 Selection of the hose and sensor installation to the hose

When selecting the hose, the inner diameter (ID) of the hose should ideally match the ID of the fluid connections of the Quattroflow Single-Use pump chamber. An ID that is too small on the suction side can lead to cavitation and, in the worst case, damage to the pump chamber. If a smaller ID is still used, the maximum volume flow must be limited so that no cavitation can occur.

The em-tec sensor must be suitable for the respective hose size. In addition, the sensor must be calibrated for the respective hose type and for the respective process (fluid, temperature, flow ranges). It is generally recommended to use single-use hoses without reinforcement (e.g. fabric), otherwise the measurement could be negatively affected.

It is recommended to install the sensor on the inlet (suction) side of the pump. This means that the hose or the measurement is not influenced by increased pressures that can occur on the pressure side of the pump, depending on the process.

When selecting the hose, care must be taken that the hose does not contract due to the negative pressure on the suction side. This can lead to cavitation and adversely affect the measurement.

The sensor should not be installed too close to the pump to avoid turbulence. The instructions on proper inflow and outflow sections upstream and downstream of the sensor must be considered (see below).

The installation and positioning of the em-tec sensor depends on the system and the application. The instructions for sensor installation and positioning in the BioProTT operating instructions must be considered.

In general, the following should be considered:

- The hose must not be deformed, damaged or contaminated
- The hose with the sensor should be positioned so that air cannot accumulate at the sensor location
- There must be no impurities in the sensor casing
- Attention must be paid to the flow direction (arrow on sensor lid)
- When the sensor lid is closed, the hose must not be damaged or deformed
- The sensor lid must be completely closed and locked
- The sensor should have a straight inlet and outlet section to avoid turbulence and associated measurement inaccuracies.
- The inlet and outlet sections should equal minimum 15 x ID of the hose

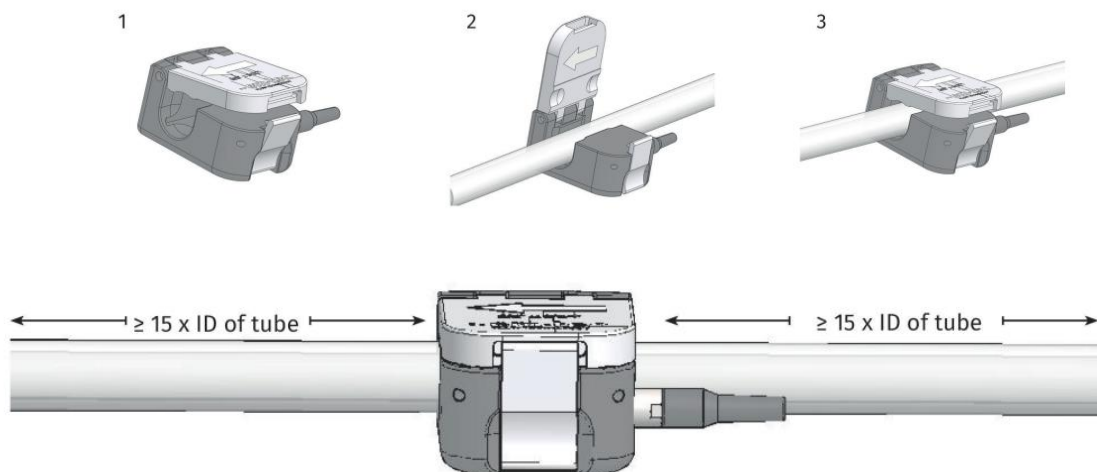

Picture 21 em-tec sensor installation at the tube

9.1.4 Parameterization of Q-Control

- Analog Input 1 must be configured according to the following table:

MENU > Settings > Analog Input 1

Signal type: 4-20 mA

Type: em-tec

Unit: *

Min Value: *

Max Value: *

* Min und Max Values depend on sensor type and calibration Please use values given in the sensor certification sheet. Alternatively, take the value from the web interface of the FlowMCP- a signal processing unit.

- Use as Master Sensor (e.g. for flow control):
MENU > Settings > Sensor Mapping > Flow > AIN1
- Option: Use of the sensor for an analog process alarm:
Define Alarm Value:
MENU > Settings > Analog Input 1 > Alarm > adjust Value
Analog-Alarm must be active:
MENU > Settings > Alarms Analog > Analog 1 > On

Selection of the sensor type *em-tec* results in the following changes:

- Adjust the lower threshold for the sensor alarm
- Allow for selection of sensor Type *RSS (em-tec)* for Analog Input 3 or 4

Activate RSS-Value

If the RSS value is to be displayed, the following adjustments are necessary:

For the use of the RSS signal please select the following:

- Configure Analog Input 4
MENU > Settings > Analog Input 4
Type: RSS

NOTE

Type *RSS* can only be selected for Analog Input 4, if Analog Input 1 is set to em-tec type and no other analog input has the RSS type setting.

Selection of type *RSS* results in the following changes:

- Unit for Analog Input is percentage (%)
- The signal value is displayed in 0 ... 100 %

- RSS value is displayed as bar graph in the following operating modes:
MANUAL RPM
FLOW CONTROL

As exemplary figure of the RSS display is shown in chapter 9.1.6

9.1.5 Scaling of measurement range and analog signal for the flow measurement

The maximum measurable volume flow Q_{Max} is stored in the calibration of the sensor. As soon as a sensor is connected to the pump, the built-in FlowMCP-a detects the sensor and the maximum value stored in Calibration Table 1 is used.

The following graph shows the linear scaling of flow rate and electrical current signal:

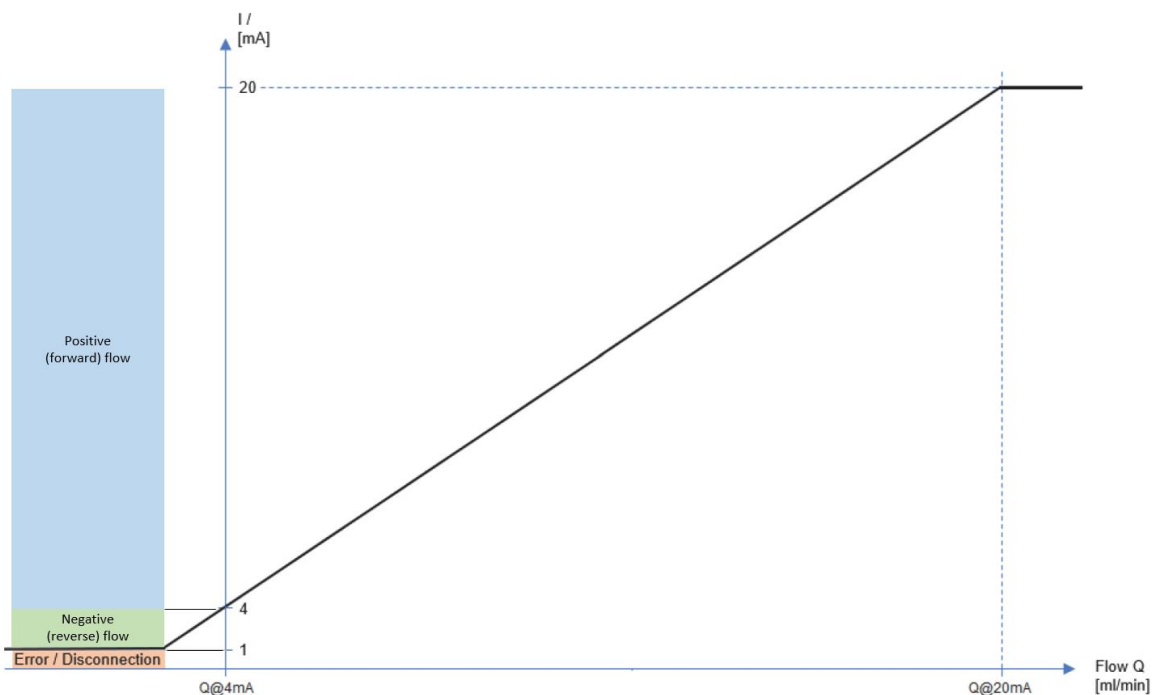

Picture 22 em-tec scaling of measuring range

The FlowMCP-a output is scaled as a standard as follows:

Analog Signal	Volume Flow
4 mA	$Q_{Min} = 0$
20 mA	Q_{Max} (depends on calibration)

Table 12 em-tec Standard Scaling of the FlowMCP-a

Example

Flow sensor size BCT 3/8 x 3/16 with a calibrated maximum volume flow of 10 LPM:

Analog Signal	Volume Flow
4 mA	0 LPM
20 mA	10 LPM

Table 13 Scaling of Analog Signal for the Volume Flow (Example)

It is recommended to have the lower value set to 0 in order to allow for correct calculation of the volume flow.

NOTE

Once a different sensor with another measurement range is connected, or another calibration table with a different measurement range is used, settings of Analog Input 1 must be altered accordingly.

Detailed description of the measurement range:

< 1 mA

Error of the measuring system. The Q-Control software displays an error message in this case. If an error occurs while the pump is running, the pump stops immediately.

While the error is active, the pump cannot be (re)started. Further information can be found in chapter 9.1.8.

$1 \leq \dots < 4 \text{ mA}$

The measuring system can evaluate negative flows in this range. If a negative flow occurs, Q-Control displays this Measurement Value with a negative sign [-] in the display.

For this purpose, the set linear slope (scaling) between 4... 20 mA calculated and linearly extrapolated to the negative range. In normal operation with a Quattroflow pump, no or only very small negative fluxes or reflows should occur.

The flow sensor and its specified accuracy are normally intended for a positive flow direction. When installing the sensor, attention must be paid to the correct flow direction (arrow on sensor)

4 ... 20 mA

Standard measurement range, positive flow direction.

> 20 ... 21 mA

If the sensor is operated above the set maximum volume flow, the sensor outputs a constant current of 20 mA and Q-Control displays the maximum set Measurement Value.

> 21 mA

There is an error of the measuring system. The Q-Control software displays an error message in this case. If an error occurs while the pump is running, the pump stops immediately.

While the error is active, the pump cannot be started.

9.1.6 Use of the RSS-Value

Displaying of the RSS-Value (Received Signal Strength) can be activated via AIN4, see chapter 9.1.4. The analog current signal (4-20 mA) of the FlowMCP-a is transformed into a voltage signal (0-10 VDC) Internal evaluation is enabled by Analog Input 4.

RSS value display in the following operating modes

MANUAL RPM
FLOW CONTROL

During use of these operating modes, RSS is displayed as horizontal bar-graph. The graph is separated in four parts with 25 % each.

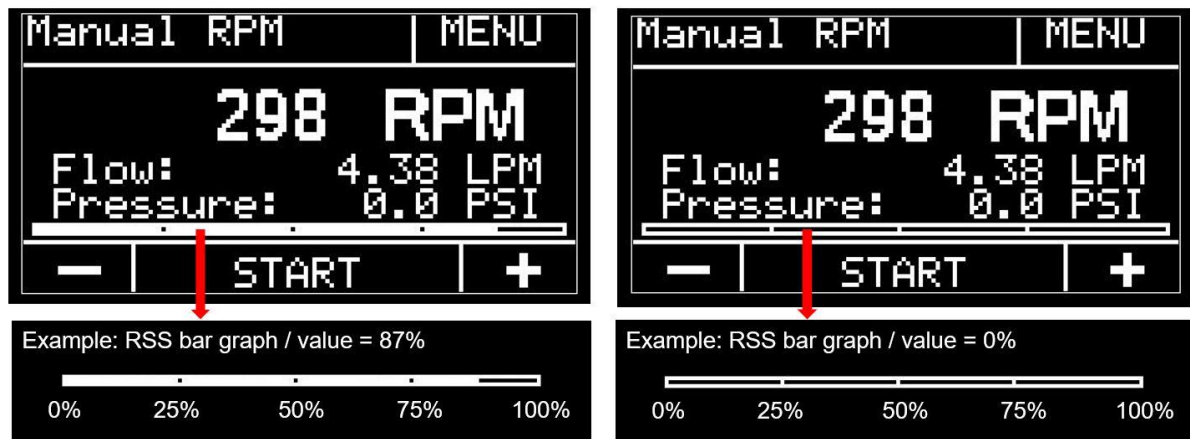

Picture 23 Display for RSS bar graph. Examples for values of 87% and 0%.

Standard scaling of RSS-Value and Analog Input 4 cannot be changed and is:

Analog Signal RSS	Analog-Signal Converted (AI4)	RSS value
4 mA	2 VDC	0 %
20 mA	10 VDC	100 %

Table 14 em-tec Standard Scaling of the RSS-Value

Internal hardware converts the electrical current signal to the voltage signal.

The RSS value must be at least 50% for operation. The system is in an error state below this value. See also chapter 9.1.8.

An RSS value > 60% is recommended for operation.

9.1.7 Use of the em-tec Sensor (zeroing and measurement)

Simultaneous use of em-tec und PendoTECH (Pump code QCON...-EP)

If the pump is equipped with both em-tec Flow Sensor and PendoTECH Pressure Sensor:

- The PendoTECH Pressure Sensor must be zeroing must be performed with are at ambient pressure, in contrast to zeroing the em-tec sensor.
- Before the start routine for em-tec (which means degassing of the system) is done, the zeroing for PendoTECH has to be finished.

Further information can be found in chapter 9.2.6.

Start-Routine em-tec (degassing and zeroing)

The em-tec flow sensor must be set to zero before any process starts, to ensure measurement accuracy.

The following points must be observed:

- **During zeroing, the fluid velocity must be zero**
- **There must be no air at the sensing position**
- **The system must be in a stationary state**
- **Flow-MCP-a does not allow for zeroing at an offset > 180 l/h**
- **Q-Control does not allow for zeroing while the pump is running. While the pump is running, the ZERO FLOW SENSOR button is out of order.**

Recommended procedure:

- The sensor must be connected and set up in the Q-Control settings
- The sensor must be correctly connected to the hose
- Select Q-Control operating mode **MANUAL RPM**
- Completely fill the system with an appropriate pump speed until there is no more air in the system.
- If a sensor alarm appears and the pump cannot be started, the process alarm for **Analog-Input 1** must be (temporarily) deactivated. As soon as the system is filled and the em-tec sensor displays an RSS value > 50%, the alarm can be reactivated if required.
- Check the RSS value in the display during the filling process. If the value is between 60 – 100%, the pump can be stopped. The system is now ready for zeroing.
- Press button **ZERO FLOW SENSOR** on the front of the pump to zero the sensor.

- During zeroing, observe the displayed flow value in the main window. After the zero switch is pressed, a Flow Value of approx. 0 should be displayed within a few seconds. This signals that the zeroing has been successfully performed.



Picture 24 em-tec successful zeroing

Re-zeroing should be performed in the following cases to achieve the highest possible measurement accuracy:

- the sensor has been disconnected from the hose
- the sensor has been disconnected from the pump
- another calibration table has been selected
- a change in the fluid and/or temperature
- if the displayed measurement value continues to deviate significantly from 0 after a zeroing (positive or negative), the zeroing must be performed again with correct conditions.

During measurement

During the measurement, the RSS value must be between 60 – 100 %. If the RSS value drops below 50%, the FlowMCP-a is in error state and the pump stops immediately. Further information is available in chapter 9.1.8.

9.1.8 Errors, trouble shooting

The FlowMCP-a monitors the state of the measuring system and outputs an error state as a current signal via the analog output for the volume flow. The Q-Control software also detects this as an error and the following error message appears:

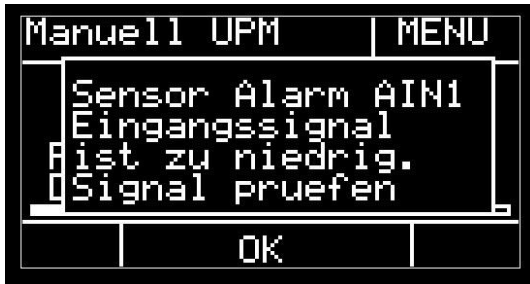

Picture 25 Sensor-Alarm example

If the error occurs during operation, the pump stops immediately. If the fault is detected in the stopped state, the pump cannot be started.

The Q-Control software cannot distinguish between different causes of errors. If possible, the entire pump should be disconnected from the power and restarted. The system takes a few seconds to be completely powerless. If the restart does not help, it must be checked whether the FlowMCP-a is switched on and supplied with power. To do this, the current signal of Analog Input 1 must be read out:

MENU > Settings > Analog Input Values > Analog 1

Value AIN1	Error Cause	Check and Remedy
0 mA	FlowMCP-a has no function	
	Blown fuse inside pump	Check fuse F1 and replace if necessary
	FlowMCP-a or wiring defective	Please contact the Quattroflow Service Team
Approx. 0,5 mA	Flow MCP-a is switched on, but in an error state	
	No sensor connected	Connect sensor
	Damage sensor wiring	Check wiring, replace sensor
	RSS-Value below < 50 %	See next section below
	Internal error of the Flow MCP-a	Read out the error in the FlowMCP-a web interface. Follow instructions in em-tec manual, according to the error code. Contact Quattroflow Service Team.

Table 15 em-tec Troubleshooting with analog-signal

RSS-Value < 50 %

If the RSS value is < 50%, the measuring system is in an error state and the analog signal for volume flow is a current value of approx. 0.5 mA.

In most cases, an RSS value < 50% is caused by air in the hose at the sensor position or the system is not completely vented. The following table shows hints on how to fix the error state:

		Error Cause	Check and Remedy
Pump switches off during operation	All operating modes	Air is present in the hose. RSS drops to < 50 %	Restart pump. If not possible, see below
		Air is permanently present in the hose. RSS drops to < 50 % e.g. upstream container is empty	If the system shall be completely emptied, use operating mode MANUAL RPM and deactivate process alarms
Pump cannot be started	All operating modes except FLOW CONTROL	The hose at the sensing position is not degassed and the RSS value is < 50%. In addition, a process alarm with sensor monitoring is activated	Temporarily deactivate process alarm for analog Input 1, until the system is filled and RSS>50%
	FLOW CONTROL	The hose at the sensing position is not degassed and the RSS value is < 50%.	Use mode MANUAL RPM to initially degas the system See section "starting routine". Switch to operating mode FLOW CONTROL afterwards.

Table 16 em-tec RSS <50%

9.1.9 FlowMCP-a Web interface

A PC / laptop connects to the Ethernet interface of the FlowMCP-a and calls up the web interface of the device. The corresponding connection is installed on the back of the pump and is made via a conventional RJ45 network cable.

The following actions can be achieved via the web interface, among others:

- Selection of the calibration table of the flow sensor (if several tables are stored in the sensor)
- Display of the Measurement Value and the RSS Value
- Configuration of the sensor
- Reading error messages for troubleshooting
- Advanced settings for the measuring system

Further information on the use of the web interface can be found in the operating instructions of em-tec.

Quattroflow Standard Configuration of the Flow MCP-a

The configuration of the integrated FlowMCP-a corresponds to the standard delivery settings from em-tec. All parameters can be accessed and modified by the web interface.

Some parameters severely influence the functionality of the FlowMCP-a in combination with the Q-Control Pump. The following tables lists parameter that must not be modified:

Parameter	Standard Value	Note
Miscellaneous		
Restore sensor settings after sensor reconnect / device restart	On	-
Clip RSS by 100%	On	For correct scaling in the Q-Control software (0–100%)
Enable error filter and allow device to reset channels	Off	-
Analog Board		
Enable/Disable Analog Output	Enable	FlowMCP-a communicates with Q-Control via Analog Signal
Flow to current	1 Hz flow average	Measurement frequency / filter time Do not use 0,1 Hz for mode FLOW CONTROL
Expand RSS range	off	Correct scaling of RSS-Value
Zero Flow Adjustment over analog input	On	Allows zeroing with the button on the pump
Flow value at 4 mA	0	Correct scaling of the Analog-Signal

Parameter	Standard Value	Note
Flow value at 20 mA	Qmax	For correct scaling of the Analog-Signal. Use the maximum sensor flow rate based on the calibration table

Table 17 em-tec web interface standard-configuration

Information on other functions are described in the em-tec manual.

9.1.10 Cleaning and disinfection of the sensor

Common household products are recommended for cleaning and disinfecting the sensor. A lint-free cloth should be used. In order to avoid residues and deposits, the sensor should be checked after each use and cleaned if necessary.



WARNING

- The sensors are not suitable for machine cleaning and sterilization.
- Remove sensors from the system during machine cleaning or sterilization.
- No cleaning agents may get into the interior of the sensor.
- The sensor must not be immersed in the cleaning agent.
- The sensor is not suitable for steam sterilization and autoclaving.

9.2 Integrated signal processing for PendoTECH Pressure Sensors – Only for SU Pumps with code QCON...-P and QCON...-EP with Firmware 02.XX.XX

9.2.1 General information

The Q-Control pump with the integrated PendoTECH PT-60 sensor transmitter is available for direct connection of a PendoTECH single-use pressure sensor. This unit is fed internally with a 24 VDC power supply and does not require a separate power supply.

The raw signal from the sensor is processed in the processor and passed on to the Q-Control as a 4-20 mA analog signal. This means that the sensor can be used like any conventional sensor with all the functions of the Q-Control pump (e.g. pressure control, pressure switch-off, data recording).

The single-use pressure sensors are not offered by Quattroflow and are not included when the pump is delivered.

Pumps with integrated PendoTECH transmitter have an additional **ZERO PRESSURE SENSOR** button.

NOTE

When using the pressure sensor for process shut-off with a process alarm, the instructions in Chapter 11.1.4 must be observed!

9.2.2 Connection to the pump

If the Q-Control pump is equipped with the integrated PendoTECH option, the flow signal is always evaluated via analog input 2 (AIN2).

This configuration cannot be changed by the user. Analog input 2 is wired internally and can therefore no longer be used for other sensors.

The PendoTECH sensor is connected to the included extension cable that has to be connected to the **Port X4** at the back of the pump.

Further information on the assignment and use of the connections can be found in chapter 18.1.2.

Note on the cable / connector: if the single-use pressure sensor is equipped with a waterproof circular connector for panel mounting, a corresponding adapter cable must be used, which is available from PendoTECH.

9.2.3 Parameterization of Q-Control

- Analog input 2 must be configured as follows:

MENU > Settings > Analog Input 2

Signal type: 4-20 mA

Type: P-TECH

Unit: bar / psi

Min Value: 0 bar / 0 psi

Max Value: 4,14 bar / 60 psi

- Use as Master-Sensor (e.g. for FLOW CONTROL):
MENU > Settings > Sensor Mapping > Pressure > AIN2

Selecting type *P-TECH* results in the following parameter changes in the software:

- Adaptation of lower and upper threshold for the sensor alarms

Option: When using the pressure sensor for pump shut-off with a process alarm

Define alarm value:

MENU > Settings > Analog Input 2 > Alarm > adjust Value

Activate analog alarm:

MENU > Settings > Alarm Analog > Analog 2 > On

NOTE

When using the pressure sensor for process shut-off with a process alarm, the instructions in chapter 11.1.4 must be observed!

9.2.4 Scaling of measurement range and analog signal

The Q-Control pump is equipped with the PT-60 sensor signal processor as standard. The measuring range is determined by the processor and not by the sensor. This means that PendoTECH pressure sensors of all sizes and designs can be used with the Q-Control pump.

The following table shows the scaling between pressure and electrical current signal for the PT-60:

current [mA]	Gauge pressure [barg]	Gauge pressure [psig]	Note
< 1,6	-	-	Error (Sensor-Alarm)
1,6	-0,62	-9	Negative gauge pressure exceeding standard measurement range (linear extrapolation)
4,0	0,00	0	Standard measurement range (linear)
20,0	4,14	60	
22,0	4,66	67	Positive gauge pressure exceeding standard measurement range (linear extrapolation)
> 22,0	-	-	Error (Sensor-Alarm)

Table 18 PendoTECH measuring ranges

Analog Input 1 for PendoTECH is scaled to the standard measurement range of the PT-60:

Analog Signal	Volume flow
4 mA	0
20 mA	4,14 bar / 60 psi

Table 19 PendoTECH Standard Scaling of PT-60

Detailed description of the measurement range:

< 1,6 mA

There is a fault in the measuring system. In this case, the Q-Control software displays an error message. If an error occurs while the pump is running, the pump stops immediately.

The pump cannot be started while the error is present.

1,6 ... < 4 mA

In this range, the measuring system can display negative relative pressures below the value after zeroing.

If a negative pressure occurs, Q-Control shows this measurement value with a negative sign [-] in the display.

For this purpose, the set linear gradient (scaling) between 4... 20 mA is calculated and linearly extrapolated into the negative range.

4 ... 20 mA

Standard measurement range for positive relative pressure

20 ... ≤ 22 mA

Pressure values above the standard measuring range are displayed.

For this purpose, the set linear gradient (scaling) between 4... 20 mA is calculated and linearly extrapolated above 20 mA.

> 22 mA

There is an error, and the Q-Control software displays an error message. If an error occurs while the pump is running, the pump stops immediately.

The pump cannot be started while the error is active. Further information on this topic can be found in chapter 9.2.7.

9.2.5 Notes on sensor selection and installation

For use with Quattroflow pumps, the pressure sensor is installed as standard downstream of the pump in order to monitor or control the pressure. In addition, the pressure sensor can be used as a pressure switch-off.

When selecting the sensor and the hose, the inner diameter (ID) should ideally match the ID of the process connections of the respective Quattroflow single-use pump chamber.

Optionally, the pressure sensor can be installed directly to the pump chamber using a tri-clamp connector. The PendoTECH sensors are available with a tri-clamp or hose connector in various dimensions.

9.2.6 Use of the PendoTECH Sensors (zeroing and measurement)

Every PendoTECH pressure sensor must be zeroed before measurement. Since the sensor measures relative pressures, the sensor is set to 0 barg during zeroing. This allows for maximum measurement accuracy.



DANGER

Sensor zeroing must not be performed when the pressure is higher than ambient pressure (> 0 barg / > 1 bara)!

After a pump stop there might be still an overpressure in the system. Zeroing during this occurrence results in an erroneous measurement. The pressure switch off will not work correctly in this case and as a result the pump might be damaged.

Following points must be observed

- **Zeroing of the PendoTECH Pressure is done when ambient air pressure is present at the measurement position**
- **Q Control allows for zeroing only when the pump is stopped. During pump run the ZERO PRESSURE SENSOR button is out of order.**

Recommended procedure:

- The sensor must be connected and set up in the Q-Control Settings
- The sensor must be correctly connected to the hose system
- There must be air in the sensor at ambient pressure
- Briefly press the **ZERO PRESSURE SENSOR** button on the front of the pump.
- While zeroing, observe the displayed measurement value for pressure in the main screen. After the zeroing button has been pressed, a measurement value of approximately 0 should be displayed within a few seconds. This signals that the zeroing has been carried out successfully.



Picture 26 PendoTECH successful zeroing

Simultaneous use of em-tec and PendoTECH (Pump code QCON...-EP)

If the pump is used with the em-tec flow sensor and PendoTECH pressure sensor, please consider the following:

- In contrast to the PendoTECH pressure sensor, the em-tec flow sensor must be zeroed when the system is filled with water.
- Before the start routine for em-tec is carried out (venting the system), the PendoTECH pressure sensor must be zeroed.

Further information can be found in section 9.1.7

9.2.7 Errors and troubleshooting

Q-Control software monitors the electrical current signal from the PendoTECH transmitter. If an error is detected, the following error message appears for analog-input 2 (AIN2):

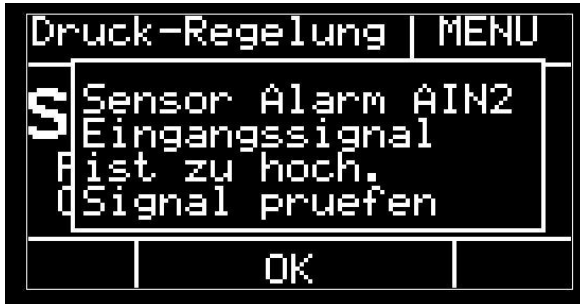

Picture 27 PendoTECH Sensor-Alarm

If an error occurs during operation, the pump stops immediately. If the error is recognized during pump stop, the pump cannot be started. Q-Control cannot differentiate between different causes of errors. If possible, the entire pump should be disconnected from the power supply and restarted. The system needs a few seconds to be completely de-energized.

If a restart does not solve the problem, the condition of the sensor transmitter must be checked. To do this, the electrical current signal for Analog Input 2 must be read out:

MENU > Settings > Analog Input Value > Analog Input 2

Value AIN2	Error Cause	Check and Remedy
0 mA	Sensor Transmitter has no function	
	Blown fuse inside pump	Check fuse F1 and replace if necessary
	Sensor Transmitter or internal wiring is defective	Please contact Quattroflow Service Team
> 22 mA	Sensor Transmitter is switched on, but in an error state	
	No sensor connected	Connect sensor
	Sensor is defective	Check and replace sensor
	Sensor wiring and/or extension cable defective	Check and replace wiring

Table 20 PendoTECH Troubleshooting

9.3 Pressure sensor Labom Pascal CS2110 (multiple-use)

9.3.1 General information

As an option for multiple-use pumps, Quattroflow offers the following pressure sensor with a switched output in various sizes:

Pressure transducer / switch

- Manufacturer: Labom
- Type 3 PASCAL CS2110
- Stainless steel diaphragm seal with TriClamp connector
- Measurement range: 0 ... 10 barg
- Analog output: 4 ... 20 mA
- Pressure switch, switching point can be configured on the sensor
- 2 floating switch contacts (NPN or PNP)



Picture 28 Exemplary picture of a Labom Pascal CS2110

NOTE

Please read the sensor manufacturer's operating instructions before using the sensor and the function in Q-Control. The user must heed and follow all of the instructions and safety instructions provided there.

Quattroflow offers customized cables in different lengths for this sensor. By default, this cable has the following assignment:

Plug type	Signal	Connection
M12, 8-pin, female	4-20 mA analog signal 24 VDC power supply	Connection at Labom pressure sensor
M12, 8-pin, male		Connection at Q-Control. Wired for: AI2 (Port X3)

Table 21 Cable Q-Control and Labom Pascal CS2110

NOTE

The standard version of the cable from Quattroflow is not made for use with the switched output. If the switched output or an alarm is to be used, please contact the Quattroflow team for more information.

9.3.2 Commissioning and parameterization

- Plug must be connected to the sensor.
- Plug must be connected to Q-Control:
AI2 (Port X3)
- The sensor must be configured according to the following table:
MENU > Setting > Analog input 2
Signal type: 4-20 mA
Type: Pressure
Unit: bar
Min value: 0,00
Max value: 10,00
- Use as a master sensor (e.g., for pressure control):
MENU > Setting > Sensor mapping > Pressure > AIN2

Using the sensor for an analog process alarm for pump shut-off

The alarm value must be defined by the user:

MENU > Setting > Analog input 2 > Alarm > Set value

Analog alarm 2 must be activated:

MENU > Setting > Analog alarms > Analog 2 > On

NOTE

If the pressure sensor is used for pressure switch-off in combination with a process alarm, please take care of chapter 11.1.4

9.4 Flow sensor em-tec BioProTT Clamp-On / FlowTrack plus

9.4.1 General information

In cooperation with em-tec, Quattroflow offers clamp-on flow sensors for use with Quattroflow pumps. The respective sensor type depends on the pump size and the type and size of the hose. Please note that the em-tec sensors must be calibrated to the corresponding hose and to the application. For more information, please contact the Quattroflow team.

This section describes the following combination:

Quattroflow pump with Q-Control

+

em-tec BioProTT Clamp-On Flow Sensor

+

em-tec BioProTT Flow Tack Plus analysis unit with 4-20 mA analog output



Picture 29 em-tec FlowTrack plus (example)



Picture 30 em-tec Clamp-on sensor (example)



**Warning: The sensors are not suitable for automated cleaning and sterilization
Remove sensors from the system during automated cleaning and sterilization**

NOTE

Please read the sensor manufacturer's operating instructions before using the sensor and the function in Q-Control. The user must heed and follow all of the instructions and safety instructions provided there.

Quattroflow offers customized cables in different lengths for this sensor. By default, this cable has the following assignment:

Plug type	Signal	Connection
M8, 4-pin, female	4-20 mA analog signal 24 VDC power supply	FlowTrack plus connection Flow 4-20 mA
M12, 8-pin, male		Connection at Q-Control. Wired for: AI1 (Port X2)

Table 22 Cable Q-Control and em-tec FlowTrack plus

NOTE

The FlowTrack plus device receives the required 24 VDC power supply via the cable assembled by Quattroflow, which connects the FlowTrack plus with the Q-Control pump. The external power pack supplied by em-tec as standard is therefore not required and must not be additionally connected. Otherwise electrical components could be damaged!

Assembled cable connection to FlowTrack plus:

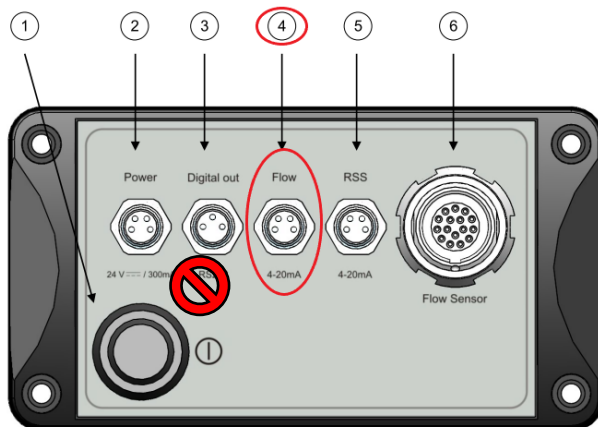

Figure 16: Rear view of BioProTT™ FlowTrack

Components	Description
1 On/Off button ①	Push the button to power the device on or off. Note: this button is only relevant when power is supplied via the power socket. The button does not affect power supplied via either Flow or RSS socket.
2 Power	4-pin connecting socket for DC power. Note: only 2 pins are actually used.
3 Digital out	3-pin connecting socket for the signal digital interface.
4 Flow	4-pin connecting socket for the analog flow signal.
5 RSS	4-pin connecting socket for the analog signal "received signal strength" (RSS).
6 Flow Sensor	16-pin connecting socket for the BioProTT™ Clamp-On Transducer connector with push and pull unlock mechanism.

Picture 31 em-tec FlowTrack plus connections

Further information on setting up and using the measurement system can be found in the operating instructions from the manufacturer, em-tec.

9.4.2 Commissioning and parameterization

- Plug must be connected to the FlowTrack plus:
Flow 4-20 mA
- Plug must be connected to Q-Control:
AI1 (Port X2)
- The sensor must be configured according to the following table:
MENU > Setting > Analog input 1
Signal type: 4-20 mA
Type: em-tec
Unit: *
Min value: *
Max value: *

* The min and max values depend on the type and calibration of the sensor. Please take the values from the em-tec data sheet or calibration certificate.

- Use as a master sensor (e.g., for flow control):
MENU > Settings > Sensor mapping > Flow > AIN1
- Optional: Using the sensor for an analog process alarm:
The alarm value must be defined by the user:
MENU > Setting > Analog input 1 > Alarm > Set value
- Analog alarm must be activated:
MENU > Setting > Analog alarms > Analog 1 > On

The standard setting for the analog outputs of the em-tec FlowTrackPlus uses the following scaling:

Analog signal	Volume flow rate
4 mA	$Q_{Min} = 0$
20 mA	$Q_{Max} \times 1,5$

Table 23 em-tec FlowTrackPlus standard scaling

Example

Flow sensor, size BCT 3/8 x 3/16, with calibration nominal volume flow rate of 10 LPM.

Analog signal	Volume flow rate
4 mA	0 LPM
20 mA	15 LPM

Table 24 em-tec FlowTrackPlus scaling example

9.4.3 Option: Using RSS-value (only special with Y-cable)

This function was implemented from Software version 02.XX.XX

FlowTrack Plus outputs the RSS-value (Received Signal Strength) as 4-20 mA analog signal. Quattroflow offers optionally a customized Y-cable for connection between Q-Control pump and FlowTrack Plus to use the RSS support in Q-Control software. The cable has the following wiring:

FlowTrack Plus Output	Signal	Q-Control Input
Flow M8, 4-pin, female	4-20 mA analog signal flow 24 VDC power supply	Port X2 AIN1: Flow AIN3: RSS M12, 8-pin, male
RSS M8, 4-pin, female	4-20 mA analog signal RSS	

Table 25 FlowTrack Plus, RSS support

At first, the analog-input for the flow signal needs to be configured as described in chapter 9.4.2

To use and display the RSS signal, the following additional changes are necessary:

- Attach connector to the FlowTrack plus:
RSS 4-20 mA
- Attach connector to Q-Control:
AI3 (Port X2)
- Configure Analog Input 3:
MENU > Setting > Analog-In 3
Type: RSS

NOTE

The RSS type can only be selected for analog input 3 if the em-tec type has been selected for an analog input and no other analog input has the RSS type setting

Selection of type RSS results in the following changes:

- Unit for Analog Input is percentage (%)
- The signal value is displayed in 0 ... 100 %
- RSS value is displayed as bar graph in the following operating modes:
MANUAL RPM
FLOW CONTROL

Further information about the usage of RSS-value can be found in chapter 9.1.6.

9.5 Diaphragm monitoring (multiple-use and single-use)

9.5.1 General information

This function is implemented as standard with a capacitive sensor with NPN switched output, which is available from Quattroflow as an accessory. If diaphragm monitoring is to be used, it is recommended that the pump is equipped with a sensor at the factory. Depending on the type of pump, a modified bearing housing is required.

The capacitive sensor trips when it comes into contact with liquid. This is the case when at least one diaphragm is defective and the flow medium leaks into the ring drive where the sensor is installed. The sensor trips with a digital alarm and the pump is switched off.

NOTE

More information and safety instructions about how to react in case of a membrane failure can be found in the operating instructions for the particular Quattroflow pump.

Sensor

Manufacturer: Rechner

Type 3 KAS-70-A12-A-M12-PTFE

Switching type: NPN

Cable length: 2 m

**NOTE: not applicable for
QF30QCON and QF150QCON pumps**



Picture 32 Sensor for diaphragm monitoring (example)

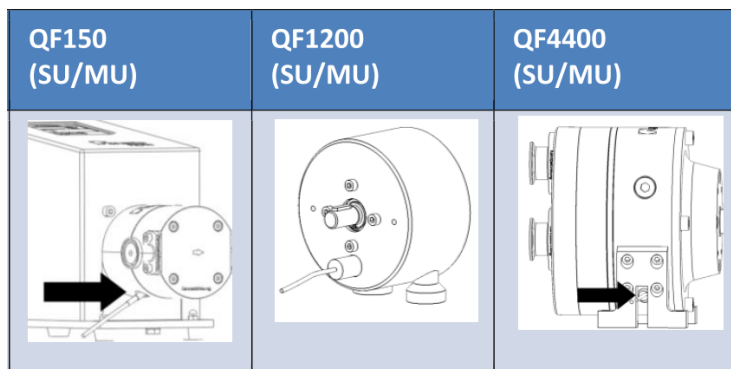

Picture 33 Quattroflow diaphragm monitoring; Example for installation

NOTE

Please read the sensor manufacturer's operating instructions before using the sensor and the function in Q-Control. The user must heed and follow all the instructions and safety instructions provided there.

The sensor is shipped with an assembled cable from Quattroflow in the following configuration:

Plug type	Signal	Connection
-	Switch signal	Permanently wired to the sensor
M12, 8-pin, male	Switch signal	Connection at Q-Control. Wired for: NPN, NC DI3 (Port X1)

Table 26 Cable Q-Control and diaphragm monitoring

9.5.2 Commissioning and parameterization

- The sensor must be installed in the ring drive.
- Plug must be connected to Q-Control:
DI3 (Port X1)
- Alarm for digital input 3 must be activated:
MENU > Setting > Digital alarms > DI3 > On
- The logic of digital input 3 must be configured correctly:
MENU > Setting > DIN inverted > Digital 3 > Off

NOTE

If the sensor is supplied by Quattroflow, the sensor is wired as NC (normally closed) and the **parameter DIN inverted** must be set to **Off**.

In this case, monitoring of the sensor and broken wire detection is active, and an alarm also appears if the sensor is removed or defective.

10 Operating modes (description, configuration, and use)

The following section describes the function, installation, and use of the various operating modes provided by Q-Control.

Some modes can only be used in combination with connected sensors. The following table shows an overview of which operating modes require a sensor, and what type of sensor:

Operating mode	Brief description	Sensor required
Manual RPM	Setting the pump speed manually Options: <ul style="list-style-type: none"> ▪ Display sensor values (Flow and pressure sensor) ▪ Totalizer 	No (only for options)
Manual flow	Setting the volume flow rate manually. The speed is calculated by Q-Control. Options: <ul style="list-style-type: none"> ▪ Totalizer 	No (only for options)
External RPM	Setting the pump speed with an external analog signal. Integration in a process management system.	No (only for options)
Dispense	Automatic mode for batch dispensing a defined volume in a specific time.	No (only for options)
Flow control	Setting a specified value for the volume flow rate. The pump uses a PID controller to control the speed.	Flow sensor with analog output Connected to: AI1...4
Pressure control	Setting a specified value for the backpressure. The pump uses a PID controller to control the speed.	Pressure sensor with analog output Connected to: AI1...4

Table 27 Operating modes

The selection list for operating modes is adapted dynamically to the settings. The following table shows the conditions for when which mode appears in the **Operating mode** selection window.

Operating mode	Conditions for displaying and selecting the operating mode
Manual RPM	Always available
Manual flow	Always available
External RPM	A signal source must be assigned to the analog signal: MENU > Settings > External control > RPM
Dispense	Always available
Flow control	A flow sensor must be assigned: MENU > Settings > Assign sensors > Flow
Pressure control	A pressure sensor must be assigned: MENU > Setting > Assign sensors > Pressure

Table 28 Dynamic displaying of the operating modes

Display of the always available selection options. The display is independent of the configuration:

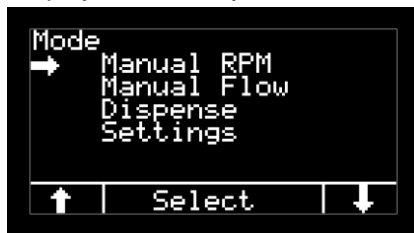

Picture 34 Always selectable modes

Display of all selection options, if the conditions for display in the configuration are fulfilled:

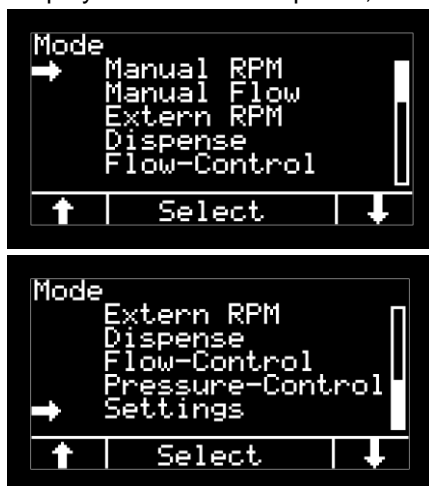

Picture 35 All selection options

10.1 Manual RPM (rotation speed)

The pump with Q-Control can be operated as a stand-alone unit with no sensor connection, and without being integrated in an external control system. In this case, it is possible to set the pump speed manually.

If the volume flow rate needs to be estimated, but there is no flow rate sensor present, this can be done using the characteristic curve of the appropriate Quattroflow pump. The pump speed with the corresponding volume flow rate can be read from the characteristic curve.

10.1.1 Installation

When the *Manual RPM* function is used, no further wiring is needed and the pump can be operated in compliance with the necessary safety requirements.

10.1.2 Use

The following exemplary picture shows the main window of the mode Manual RPM:



Picture 36 Manuel RPM; main window

Symbol button	Function button
-	Reduce speed [RPM]. Press and hold to change the value quickly.
+	Increase speed [RPM]. Press and hold to change the value quickly.
START	Start pump
STOP	Stop pump

Table 29 Manual RPM; control elements

10.1.3 Option: Display sensor value

The *Manual RPM* mode provides the option of displaying the sensor values from the flow sensor and/or the pressure sensor, if they are connected and configured.

Conditions for use:

- The flow sensor and/or pressure sensor must be connected to **Analog input 1..4**.
- The flow sensor and/or pressure sensor must be assigned as the master sensor:
MENU > Settings > Sensor mapping
- The flow sensor and/or pressure sensor must have parameters set:
MENU > Settings > Analog input 1...4

The values are displayed on the right side of the main window, below the speed:

F: Volume flow rate [Unit]

P: Pressure [Unit]

The unit for the displayed volume flow rate is based on the following settings:

MENU > Settings > Parameter 1 > Unit F

MENU > Settings > Parameter 1 > Unit P

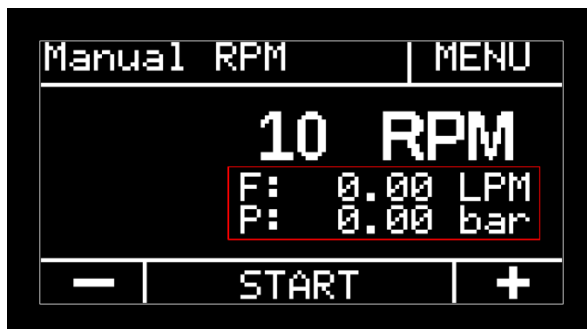

Picture 37 Manuel RPM; display sensor values (example)

If invalid measuring values are detected, that are outside the measuring range, dashes are shown in the display. If USB logging is active, these data are logged as zeros. See chapter 13 for more information.



Picture 38 Display invalid measurement data

10.1.4 Option: Totalizer

The *Manual RPM* mode includes a totalizer function that calculates the total pumped volume. The totalizer is displayed on the left side of the main window, below the speed:

Total: Volume [l]

The unit is permanently set to liters [l].

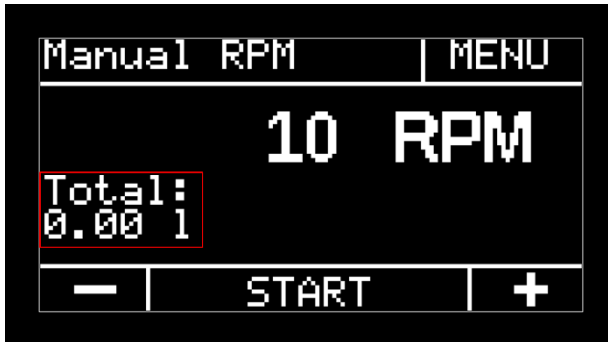

Picture 39 Manual RPM; totalizer (example)

The volume can be calculated either internally or by means of a flow sensor. For more information, see section 12.1

10.1.5 Option: Display of RSS value for em-tec flow sensors

This function was implemented from Software version 02.XX.XX

If the pump is equipped with integrated option em-tec (FlowMCP-a), alternatively with the external signal processor FlowTrack Plus, the RSS value can be displayed optionally. Further information can be found in chapter 9.1.6.

10.2 Manual flow

In this mode, the volume flow rate can be entered manually as a specified value. Using the setting for displaced volume per revolution (calibration factor), Q-Control calculates the pump speed required and sets it automatically.

Please note that the pump calculates the flow rate using a fixed value for the factor and therefore does not take backpressure into account. The accuracy of the calculation depends on the process conditions, such as backpressure, and can be improved by calibrating under operating conditions.

10.2.1 Installation

When the *Manual flow* function is used, no further wiring is needed and the pump can be operated in compliance with the necessary safety requirements.

10.2.2 Configuration

Check the calibration factor (displacement volume) or change the value manually:

MENU > Settings > Parameter 1 > Cal [ml/rev]

For more information on setting and optimizing the calibration factor, see section 12.2.

10.2.3 Use

The following exemplary picture shows the main window of the mode Manual Flow:



Picture 40 Manual Flow; main window (example)

In the second line below the flow rate, the calculated pump rotation speed with the unit RPM is shown.

Symbol button	Function button
-	Reduce volume flow rate. Press and hold to change the value quickly.
+	Increase volume flow rate. Press and hold to change the value quickly.
START	Start pump
STOP	Stop pump

Table 30 Manual Flow; control elements

The unit for the volume flow rate is based on the following settings:

MENU > Settings > Parameter 1 > Unit F

10.2.4 Option: Totalizer

The *Manual flow* mode has a totalizer function that shows the cumulative value of volume flow. The totalizer is displayed in the bottom line of the main window, below the speed:

Total: Volume [l]

The unit is permanently set to liters [l].

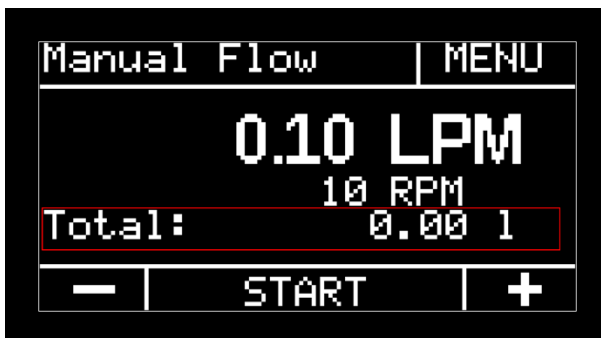

Picture 41 Manual Flow; totalizer (example)

The volume can be calculated either internally or by means of a flow sensor. For more information, see section 12.1.

10.3 External UPM (rotation speed via an external remote control)

The pump with Q-Control provides the ability to be controlled by a customer's automated process control system. In the *External RPM* operating mode, the target speed is provided via an external analog signal (4...20 mA).

10.3.1 Installation

The signal cable from the external controller must be connected to one of the four analog inputs on the back of the pump.

10.3.2 Configuration

In order to be able to select the *External RPM* operating mode, the source for the external analog signal must be selected:

MENU > Settings > External control > External RPM

The following conditions apply when selecting the signal source:

- The analog input must not simultaneously be used for a master sensor:
MENU > Settings > Sensor mapping

If this condition is not met, the following error message appears:

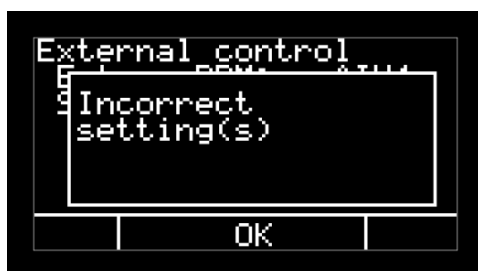

Picture 42 Error message; External control; Incorrect settings

In this case, select a different signal source for the External Control or remove the signal source in the **Sensor Mapping** settings.

10.3.3 Use

The main window shows the current speed [RPM] and the current volume flow calculated from the speed and displacement volume. The unit for the volume flow rate is based on the following settings:

MENU > Settings > Parameter 1 > Unit F



Picture 43 Extern RPM; main window (example)

Symbol button	Function button
START	Start pump
STOP	Stop pump

Table 31 External RPM; control elements

The pump can optionally be started and stopped via an external signal. For more information, see section 12.5.

10.3.4 Scaling

The conversion between the analog signal and the speed is based on linear scaling with the following minimum and maximum values:

Analog signal	Pump speed
4 mA	0 UPM Identical for all pump models
20 mA	Max. UPM Based on the particular pump model and cannot be changed by the user.

Table 32 External RPM; scaling current signal

The maximum speeds defined by Quattroflow can be found in the corresponding data sheets of the pump model.

NOTE:

The maximum values defined by the user in **MENU > Settings > Max values** are used in the *External RPM* mode.

The following diagram shows an example of a characteristic curve for the QF150 Q-Control pump, with a maximum speed of 3000 RPM:

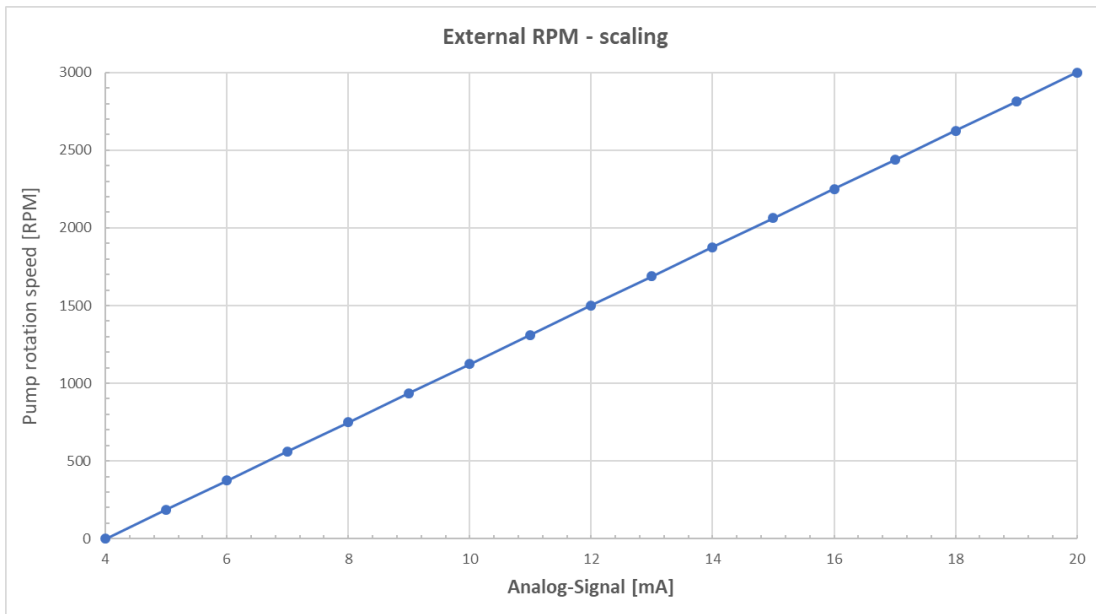

Picture 44 Graph for scaling current signal for mode External RPM; example for QF150QCon (max. 3000 RPM)

10.4 Dispensing

In this mode, automated batch dispensing can be performed. For example, this function can perform filling tasks in which the same volume needs to be dispensed multiple times within a particular time. Q-Control uses various parameter settings to calculate the necessary speed for the pump. A waiting period between the individual dispensing steps can also be set.

In order to achieve the highest possible accuracy when dispensing, it is recommended that the displacement volume per revolution (calibration factor) be determined specifically for the process. This calibration should be performed with the same process and system properties as will be used in the actual process. For more information on setting and optimizing the calibration factor, see section 12.2.

Please note that the Quattroflow feed chamber should be completely bled when calibrating and dispensing, in order to achieve the best possible accuracy and repeatability. For more information on this topic, see the general Operation Manual and the “Installation and Operation Guide”.

10.4.1 Installation

When using the *Dispensing* function, no further wiring is required, and the pump can be operated in compliance with the necessary safety requirements.

10.4.2 Configuration

Make the settings for dispensing in the following menu:

MENU > Settings > Dispensing

Parameter	Description
Unit	Unit for the dispensing volume [ml] or [l] or [gal]
Volume	Set the volume using the unit defined in Line 1
Cycles	Number of cycles
Run [s]	Time for dispensing the volume set in Line 2
Wait [s]	Pause time between each individual dispensing

Table 33 Dispensing; configuration

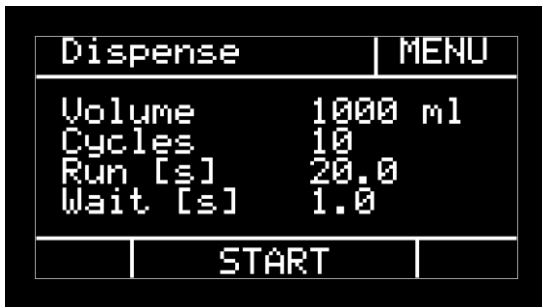

Picture 45 Dispense; configuration (example)

Q-Control uses the following parameters to calculate the necessary speed for the pump.

- Volume
- Running time
- Slope **MENU > Settings > Parameter 1 > Slope [%/s]**
- Maximum motor speed **MENU > Settings > Max values > Max RPM**
- Minimum motor speed (defined by manufacturer)

The limits for the three parameters indicated, *volume*, *run*, *wait* are calculated dynamically and independently of each other when the user changes the numerical values. If a combination of numbers is impossible the following popup window appears:

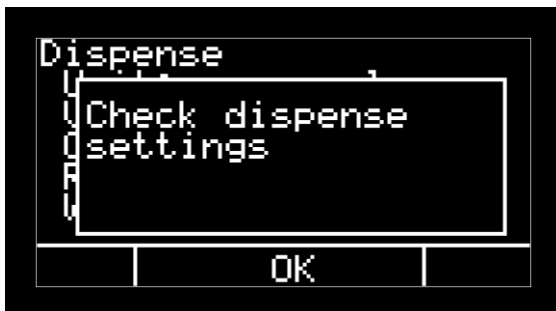

Picture 46 Error message for dispense settings

In this case, the values must be manually changed in order to make dispensing possible from a technical perspective.

As a general rule for all pump models: if the greatest possible volume is to be dispensed in the shortest possible time, the value for the slope must be increased so that the motor can accelerate faster. The maximum value for the speed must be also be increased if this parameter has been limited to lower speeds by the user.

For more information on the *Max RPM* parameter, see Section 12.3.2.

For more information on the *Slope* parameter, see Section 12.4.

10.4.3 Use

The following exemplary picture shows the main window for the operating mode Dispense.

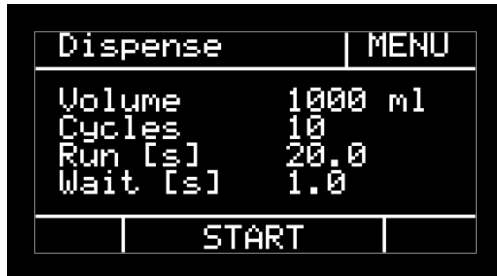

Picture 47 Dispense; main window (example)

Symbol button	Function button
START	Start automatic dispensing function
STOP	Stop pump

Table 34 Dispense; control elements

If the automatic dispensing process is interrupted by pressing the **STOP** button, or if the pump is stopped by an alarm, the counter for the number of cycles is reset to the original value and the metering process must be started again from the beginning.

10.4.4 Example application: Dispense

The pump has a filling mode that can be used to dispense a predefined volume of fluid automatically. This mode can be used for dividing a volumes into equal size in separate containers by means of the Quattroflow pump. The pump is controlled using a calibration factor that corresponds to the volume of volume displaced per revolution. No external sensors or scales are required. The displaced volume is defined as a factory setting, but can be adapted to particular conditions as needed to increase the precision of the dispensed volume. The inlet pressure, suction height, backpressure, viscosity, etc. can thus influence the calibration factor. Section 12.2 describes the calibration procedure.

Procedure:

An example of a filling setup is shown in Picture 50. In order to prevent the fluid from flowing onward after the pump has stopped, it is recommended that the storage container be located below the pump and the filling be done above the pump. Prior to starting the filling process, the pump must be completely filled and bled, which should be done in manual mode. Next, enter the filling parameters in the parameter settings (Picture 48). Enter the volume to be filled and the associated unit, the number of filling cycles, the filling time, and the pause between two filling cycles. The entry is not accepted, if the volume to be filled and specified time period exceeds the maximum volume flow rate of the pump.

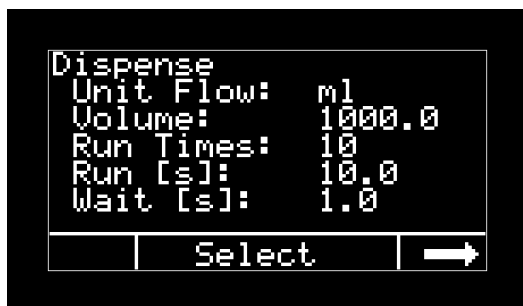

Picture 48 Parameter settings for filling mode

When the parameters have been set, call up the filling mode. Press the START button to automatically start filling to the specified volume. This ends when all filling cycles have been completed.



Picture 49 Main window Dispense mode

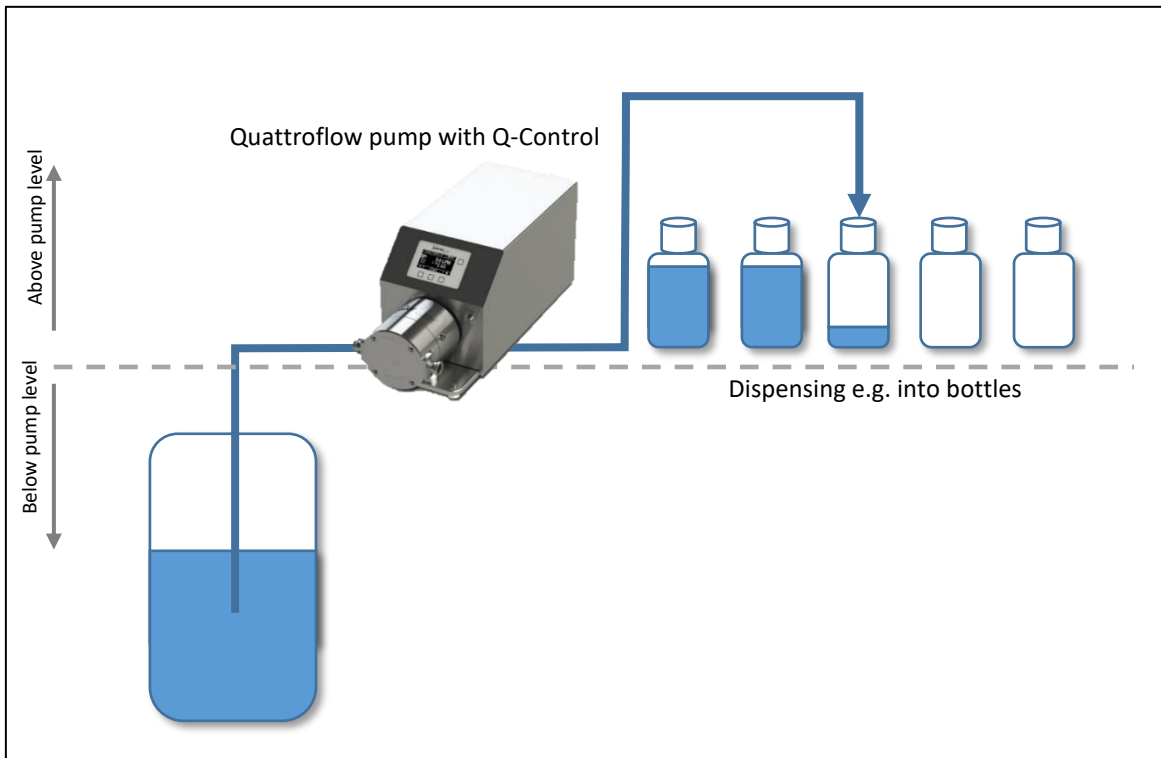

Picture 50 Example of a setup for a filling application

The maximum filling amount per unit of time for various pump sizes can be found in the following graph. These are approximate values for the standard configuration of a particular pump size.

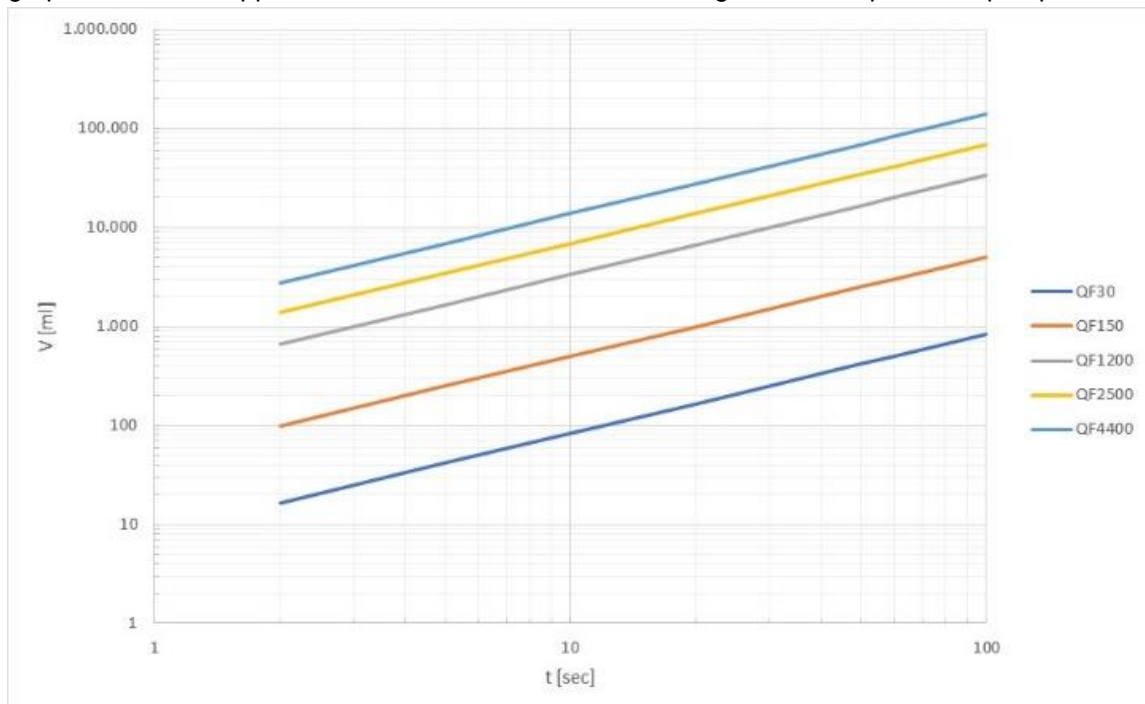

Picture 51 Maximum filling volume per unit of time

10.5 Flow control and pressure control

The two control modes allow a target value to be set manually for the volume flow or backpressure. The pump automatically controls the speed in order to reach or maintain the target value. The control is implemented as a PID (Proportional Integral Differential) controller, which provides fast and stable control in many process situations.

The flow control mode is suitable for processes in which a constant volume flow rate is to be produced over a long period of time. If the backpressure changes during the process, for example due to a full filter, Q-Control increases the speed of the pump until the set target value has been reached.

Pressure control is used for processes where the pressure is to be held constant. This is often the case for filtration processes, where a defined pressure is to be held constant before or after the filter. Example: if the filter becomes clogged over time and therefore the backpressure that it generates increases, the pump would automatically reduce the speed and therefore the volume flow rate of the pump in order to keep the pressure constant.

10.5.1 Installation

When using the *Flow or pressure control* function, a flow sensor or pressure sensor must be connected to one of the four analog inputs on the back of the pump.

10.5.2 Configuration

Conditions for use:

- The flow sensor and/or pressure sensor must be connected to **Analog input 1...4**.
- The flow sensor and/or pressure sensor must be assigned as the master sensor:
MENU > Settings > Sensor Mapping
- The flow sensor and/or pressure sensor must have parameters set:
MENU > Settings > Analog input 1...4

10.5.3 Use

The main display in flow or pressure control mode shows the following information:



Picture 52 Flow-Control; main window (example)



Picture 53 Pressure-Control; main window (example)

Symbol button	Function button
-	Reduce target value (SP). Press and hold to change the value quickly.
+	Increase target value (SP). Press and hold to change the value quickly.
START	Start pump and controller
STOP	Stop pump

Table 35 Flow- and pressure control; control elements

Explanation of the values displayed in the main window:

Abbreviation	Property
SP	Setpoint for volume flow rate or backpressure Unit from: MENU > Settings > Parameter 1 > Unit F / Unit P The maximum target value that can be set depends on the following parameters. The lesser value of the two following parameters is used as the upper limit for the SP: MENU > Settings > Maximum values > Max F / Max P MENU > Settings > Analog input 1...4 > Max value
PV	Actual value (process value) for volume flow rate or backpressure Unit from MENU > Settings > Parameter 1 > Unit F / Unit P
CV	Control variable [RPM]

Table 36 Flow- and pressure control; abbreviations

NOTE:

The maximum values defined by the user in **MENU > Settings > Max values > Max RPM** are not used in the *Flow and pressure control* mode.

WARNING

Depending on the process characteristics and the parameters set in the Q-Control, it is possible that the pump could automatically increase the speed or volume flow rate of the pump in a short time.

It must be ensured that the system can withstand overpressure and that the pump can be shut off by the user at any time in order to prevent a hazard to the system and/or personnel.

If the operating mode is controlled externally (e.g., external start/stop or RS485), and no user is working directly at the pump, then the protection against overpressure must be automatic.

10.5.1 Option: Display of RSS value for em-tec flow sensors

This function was implemented from Software version 02.XX.XX

If the pump is equipped with integrated option em-tec (FlowMCP-a), alternatively with the external signal processor FlowTrack Plus, the RSS value can be displayed optionally. Further information can be found in chapter 9.1.6.

10.5.2 PID values and Autotune

The PID parameters set in the Q-Control at the factory are sufficient for many combinations of Quattroflow pump and process. Depending on the sensor used and the process conditions, it may be necessary to optimize these parameters. This can be the case if the control is not stable (e.g., severe overshoot, not reaching the target value). Even if the control is stable, it can sometimes make sense to optimize the PID parameters, for example to achieve faster control, if this is required by the process. This section presents two methods for optimizing PID parameters. The automatic variant uses the autotune function, and the values can be changed manually. Settings can be made in the following menu:

MENU > Settings > PID Flow control

MENU > Settings > PID Pressure control

Parameter	Description
Kp	Parameter for the proportional part of the transfer function
Ki	Parameter for the integral part of the transfer function.
Kd	Parameter for the differential part of the transfer function.
AT Start [%]	Starting value for autotune (speed) % of the maximum speed (RPM) specified by the manufacturer. Max. Speed depends on the pump model.
AT Delta [%]	The mix/max speed of oscillation (amplitude) about the starting value during autotuning % of the maximum speed specified by the manufacturer. Max. Speed depends on the pump model. Condition: AT Delta [%] ≤ AT Start [%]

Table 37 Flow- and pressure control; configuration

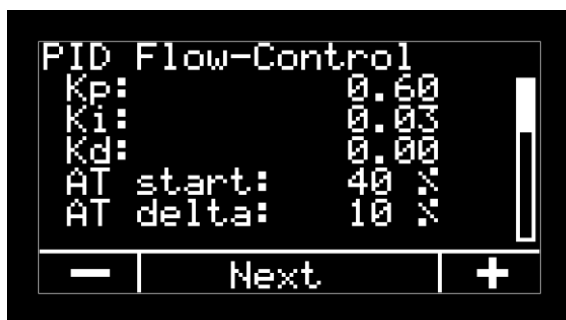

Picture 54 Flow-Control; configuration (example)

Autotune

Autotune is a procedure to automatically determine the control parameters K_p , K_i , and K_d . In this method, the pump starts at a predefined speed and maintains it constantly for a particular length of time. The speed then oscillates about this starting value for a particular length of time. Q-Control then derives the optimal control parameters from the resulting behavior of the process parameter (CV).

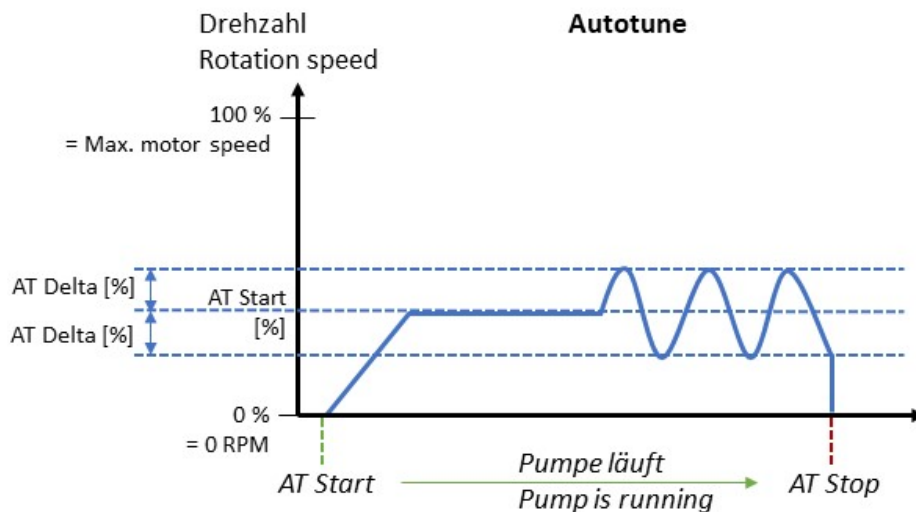

Picture 55 Flow- and pressure control; exemplary progress of the autotune

Example for QF150 series with a maximum speed of 3000 RPM set by the manufacturer:

Example parameters:

AT Start [%]: 30

AT Delta [%]: 10

Conversion:

AT Start [%]: $3000 \text{ RPM} \cdot 0.3 = 900 \text{ UPM}$

AT Delta [%]: $3000 \text{ RPM} \cdot 0.1 = 300 \text{ UPM}$

- ➔ The autotune procedure starts at 900 RPM and oscillates during the procedure by $\pm 300 \text{ RPM}$.
- ➔ The resulting speed range during the autotune procedure is 600 ... 1200 RPM.

WARNING

Depending on the process characteristics and the parameters set in the Q-Control, it is possible that the pump could automatically increase the speed or volume flow rate of the pump in a short time.

It must be ensured that the system can withstand overpressure and that the pump can be shut off by the user at any time in order to prevent a hazard to the system and/or personnel. It is strongly recommended to perform a test run of the pump at the maximum speed that can occur according to the parameters **AT Start** and **AT Delta**, and to verify that the resulting backpressure is permissible.

If the operating mode is controlled externally (e.g., external start/stop or RS485), and no user is working directly at the pump, then the protection against overpressure must be automatic.

The following methodology is recommended for performing autotune:

- Make sure that the system and the pump are protected against overpressure.
- Use the autotune function under real process conditions as much as possible in order to get the best results for the optimization.
- Define the following two parameters:
MENU > Settings > PID pressure control / PID flow control > AT Start [%]
MENU > Settings > PID pressure control / PID flow control > AT Delta [%]
 It is recommended to start with small values.

AT Delta should be about 1/3 of **AT Start** as a general guideline.

Recommended starting values:

AT Start [%]: 30

AT Delta [%]: 10

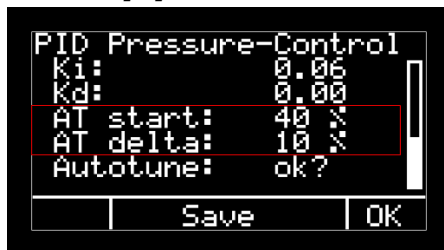

Picture 56 Set values for autotune

- Perform autotune:
MENU > Settings > PID pressure control / PID flow control > Autotune > OK

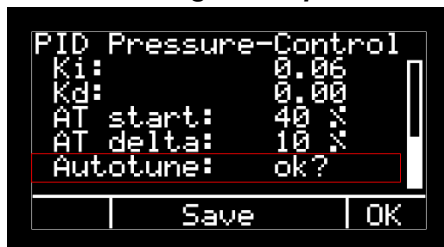

Picture 57 Start Autotune

- Confirm popup with **YES**

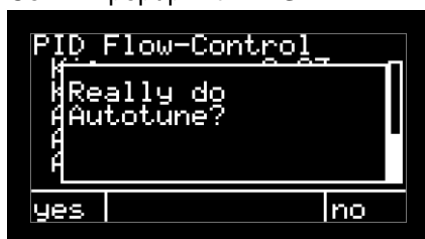

Picture 58 Popup Really do Autotune?

In case of a displaying error message, please see the section “error message” below.

- Wait until the autotune procedure has stopped automatically. While autotune is running, a popup is displayed:

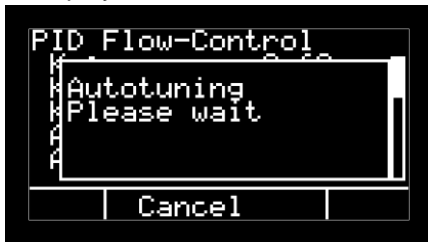

Picture 59 Popup Autotuning Please Wait

- If needed, the autotune procedure can be interrupted manually with the **CANCEL** button.
- The PID values determined (Kp, Ki, Kd) are then shown as a popup and in the menu.

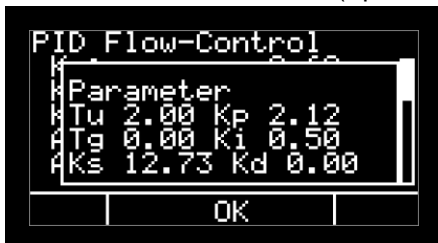

Picture 60 Popup after successful Autotune

- The controller can now be tested and started in the appropriate operating mode.

NOTE

Autotune can be run multiple times. The previously derived or manually set PID values Kp Ki Kp are then overwritten.

Error message Autotune:

If the following error message appears when starting the autotune, the autotune cannot be performed because no flow sensor has been configured.



Picture 61 Error message autotune (Example for Flow control)

In this case please check if a flow or pressure sensor is correctly connected and configured to the pump.

Furthermore, the flow or pressure sensor must be set as master sensor in the **Sensor Mapping** settings.

Manually adjustment the PID parameters

The PID parameters can be changed manually. Either an autotune can be started to get preliminary starting values, or the starting values recommended below can be used or changed.

The following instructions provide basic overview of the effects of the individual parameters. The optimal parameters ultimately depend on the pump, in combination with the process conditions. Change the values in small increments only, and then check the control function. If an autotune has been run in the meanwhile, then the currently set values are overwritten.

Parameter	Theoretical background	Influence on controller	Recommended starting values
Kp	The proportional part helps to respond quickly in case of a control deviation, but cannot entirely compensate for the deviation. As the P value increases, the control deviation gets smaller. However, the risk of overshoot also increases and damping becomes worse.	Increase value for faster response. Reduce if oscillations or overshoot are too severe.	0,40 Depending on model of pump + sensor
Ki	Compensates for control deviations. If the controller overshoots, this value should be reduced.	If Kp is increased, then Ki can also be increased in order to accelerate the control. Reduce if oscillations or overshoot are too severe. If a control deviation persists, increase the value.	0.20 Depending on model of pump + sensor
Kd	Compensating for the I component with the D component. The differential part can only differentiate, not control. It evaluates the control deviation and calculates its speed of change so that the controller can react as soon as changes are indicated.	It has been found that in many cases, a PI controller without a D component brings sufficiently good results for flow and pressure control.	0,00 Depending on model of pump + sensor

Table 38 Flow- and pressure control; PID values

10.5.3 Influence of the Slope parameter on the controller and autotune

In order to obtain stable control and good values from the autotune function, the parameter **Slope** should not be set too low. In this case, the motor would respond only very slowly, which can negatively influence the controller and the autotune function.

10.5.4 Influence of filter time on the controller and autotune

For many sensors a filter time can be set. This filter gives mean values as sensor output to reduce fluctuations from the raw signal.

Too long filter times can lead to delayed reaction of of Q-Control, which can be critical e.g. in case of alarms. In this case, the filter time of the sensor must be reduced or deactivated.

Q-Control does not allow to set an internal filter time.

10.5.5 PID Error for Options em-tec / PendoTECH

This function was implemented from Software version 02.XX.XX

In the flow and pressure control mode, a check is permanently active in the background that compares the sensor values with the speed of the pump. This will prevent a malfunction of the PID control, which can lead to the pump being accidentally accelerated to the maximum speed in short time.

NOTE

The function can possibly detect a faulty installation of the sensors caused by the user. It is not a safety function and the user must always ensure that the sensors are correctly installed before operation.

Depending on the setup and operating conditions, the function cannot always detect a faulty installation, especially in pressure control mode.

The following errors can be detected when installing the sensors:

- em-tec flow sensor is not connected to the hose in the correct flow direction
The measured value of the sensor falls below 4 mA and thus into the negative range
- PendoTECH pressure sensor is connected to the suction side of the pump
The measured value of the sensor falls below 4 mA and thus into the negative range

The following error message appears and the pump stops immediately:

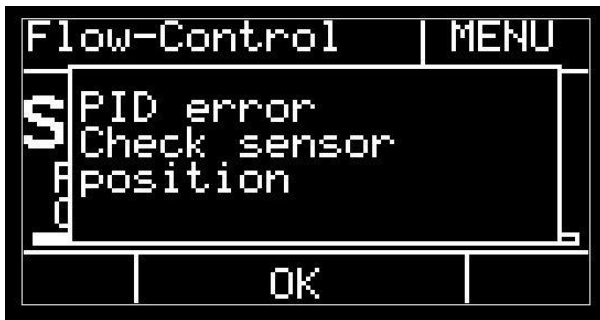

Picture 62 Error message: PID error

In this case, check whether the sensors are installed correctly:

- em-tec flow sensor → installation on the hose in the direction of flow (see arrow on sensor)
- PendoTECH pressure sensor → installation on the outlet side (pressure side) of the pump

Trigger conditions for PID errors

The following two conditions must occur at the same time:

- 1)) The sensor value has a negative sign and is less than 5% of the positive max. value from the corresponding analog input
- 2)) Pump speed is higher than 20% of the maximum speed (preset by the manufacturer)

Example

em-tec flow sensor has a max. value of 10 LPM in the analog-input

5 % = 0,5 LPM

with negative sign: < - **0,5 LPM**

PendoTECH pressure sensor has a max. value of 4,14 bar in the analog-input

5 % = 0,207 bar

with negative sign: < - **0,207 bar**

Gleichzeitig muss folgende Bedingung auftreten:

QF1200QCON pump with max. rotation speed of 2400 RPM

20 % = 480 RPM

Trigger for error: > **480 RPM**

The pump stops as soon as the speed is increased by the PID control above 480 RPM

10.5.6 Example application: Filtration with pressure control

The backpressure in a filtration application depends among other influences on the volume flow rate of the medium to be filtered. The pressure can thus be controlled indirectly by changing the pump speed. To implement pressure-controlled filtration, a pressure sensor with a 4-20mA analog output is wired to the Quattroflow pump. The pump can supply the power to the sensor directly if 24VDC voltage is required. .

Procedure:

- System setup and connection of all signal lines
- Signal input configuration per Section 5.3
- if needed set a maximum pressure for shutting off the pump per Section 11.1.4
- Fill and prime the system completely in manual mode, ensuring that the permissible pressures are not exceeded
- Switch to pressure control mode (P-Control)
- Perform Autotune per Section 10.5.2, ensuring that the permissible pressures are not exceeded
- Select the target value for pressure control (SP)
- Start pressure control
- As soon as the storage container has been emptied, the pump must be stopped manually.

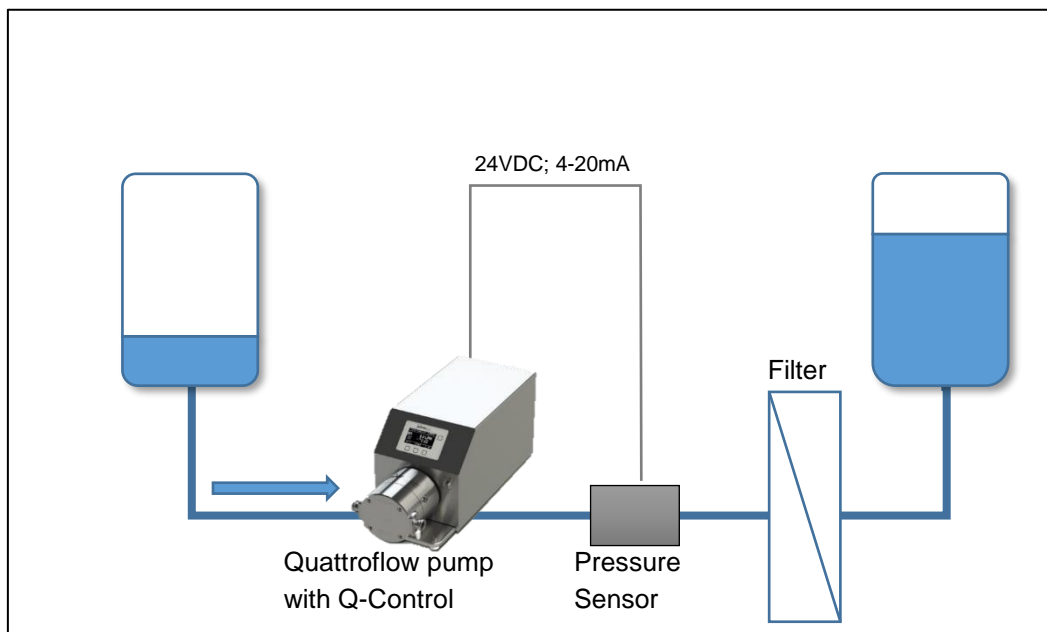

Picture 63 Example of a filtration setup with pressure control

10.5.7 Example application: Flow control with tangential flow filtration

In tangential flow filtration (TFF), the necessary cross- flow is controlled via the speed of the recirculation pump. The cross- flow is measured by a flow sensor that is typically located at the outlet of the TFF module (retentate flow). The 4-20mA analog signal from the sensor is sent to the Q-Control to control the volume flow rate. The required transmembrane pressure (TMP) is set manually in the retentate flow line by means of a control valve (TMP is not directly controlled by the pump). Overpressure shutoff can be performed by using an additional pressure sensor located between the pump and the TFF module.

Procedure:

- System construction and connection of all signal lines
- Signal input configuration per Section 5.3
- If needed set a maximum pressure for shutting off the pump per Section 11.1.4
- Fill and prime the system completely in manual mode, ensuring that the permissible pressures are not exceeded
- Switch to flow control mode (Flow control)
- Perform Autotune per Section 10.5.2, ensuring that the permissible pressures are not exceeded
- Select the target value for pressure control (SP)
- Start flow control
- Manual TMP setting
- Stop the pump as soon as the target volume or concentration has been reached in the recirculation container.

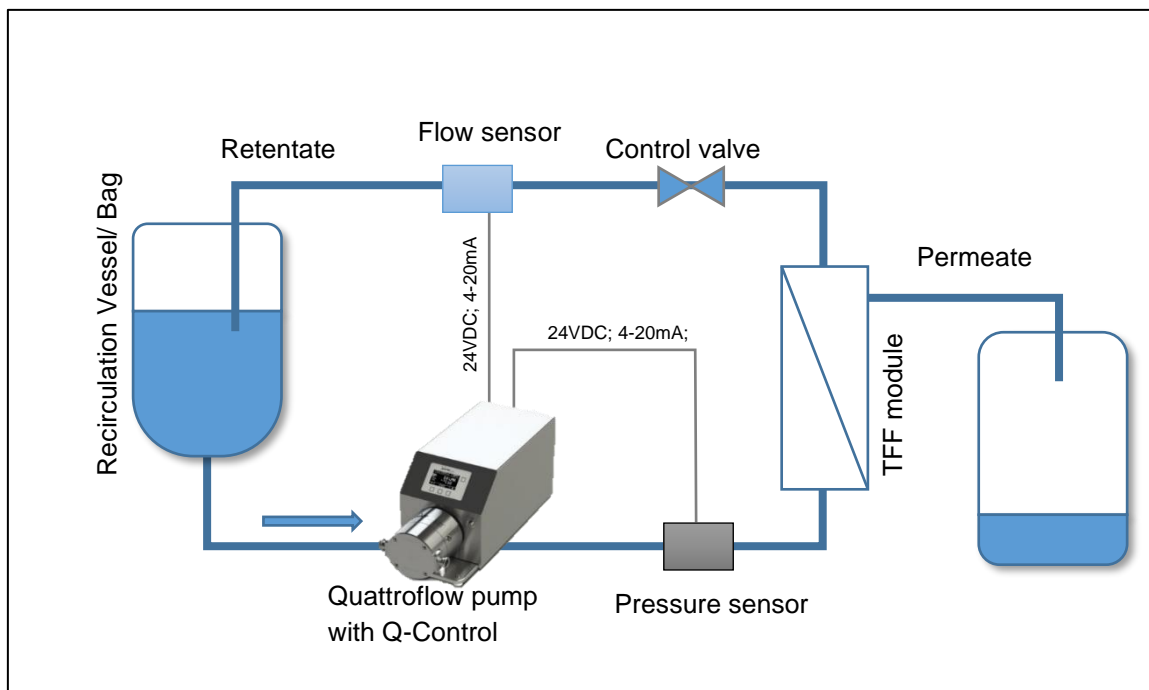

Picture 64 Example of setup for tangential flow filtration (TFF)

11 Alarms

11.1 Process alarms (can be activated by the user)

The Q-Control provides users the ability to set up process alarms for the digital and analog inputs. One alarm is assigned to each analog and digital input.

- An activated alarm is active in every operating mode.
- When an alarm trips, the pump immediately stops.
- An alarm in the **Dispense** operating mode resets the current dispense and the process must be started from the beginning.

11.1.1 Process Alarms for analog inputs

For each analog input, the user can set a self-defined process value at which the pump should stop automatically. For this purpose, Q-Control evaluates the signal from the analog input or the corresponding sensor.

The alarm value must be defined

MENU > Setting > Analog input 1...4 > Alarm

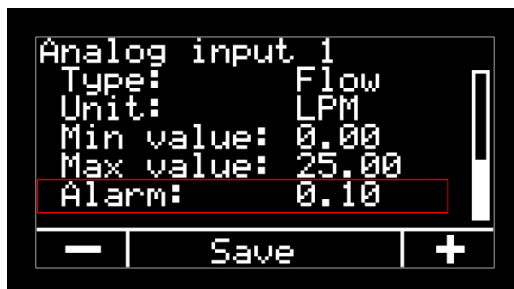

Picture 65 Set alarm value (example)

The maximum value for an alarm corresponds to the set value for parameter **Max. Value**.

The unit for an alarm corresponds with the set value for parameter **Unit**.

No process alarm can be set for Type **RSS** (for option em-tec flow sensor).

Activate alarm

MENU > Setting > Analog alarms > Analog 1...4 > On

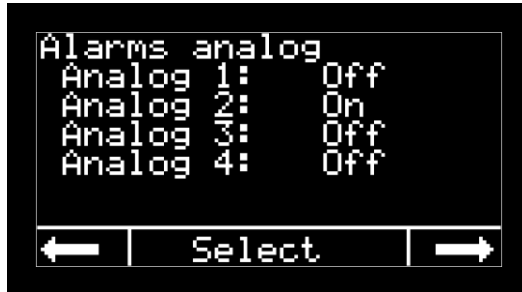

Picture 66 Alarm analog (example)

If an analog input type is set to **RSS**, no alarm can be activated. The respective line is not shown.

How it works in the event of an alarm

When this value is reached, the pump stops automatically and a pop-up message is displayed:



Picture 67 Alarm message (example)

The alarm message shows the following information:

- 1st line: Analog input that triggered the alarm
- 2nd line: Numerical value at which the alarm was triggered (in the unit configured in the settings for the analog input concerned)
- 3rd line: Set alarm value that has been exceeded

The alarm can be acknowledged by pressing the **OK** button. Now the pump can then be started again.

11.1.2 Process alarms digital inputs

Q-Control checks whether the logic (0/1 or positive / negative) of the digital inputs changes and whether it corresponds to the logic set by the user. One digital alarm can be set for each digital input (DIN1, DIN2, DIN3).

Activate alarm

MENU > Setting > Alarms digital > Digital 1...3 > On

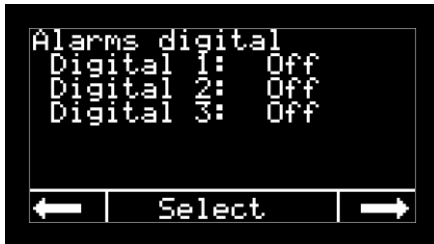

Picture 68 Alarm digital; configuration (example)

Configure the logic of the digital input

MENU > Setting > DIN inverted



Picture 69 DIN inverted (example)

How it works in the event of an alarm

When the digital signal input detects a change in the logic, the pump stops automatically and a pop-up message appears that shows the digital input, which triggered the alarm.



Picture 70 Message for digital alarm

The alarm can be acknowledged by pressing the **OK** button. Now the pump can then be started again.

NOTE

An equal message will be produced by a sensor alarm. See chapter 11.2.1.

11.1.3 Influence of a filter time on the process alarms

Many sensors have the option of setting a filter time. In most cases this means that the measured values are averaged over a set period of time in the sensor and the averaged value is output as a signal at longer time intervals.

A filter time that is too long can lead to a lag in detecting a critical process condition and thus an alarm. Make sure that the filter time setting is short enough or is deactivated.

Q-Control does not have any way to set an internal filter time.

11.1.4 Special process alarm: Pressure shut-off

NOTE:

The pressure monitor is a process alarm that shuts off the pump at a preset alarm value. This function is **not** a safety shut-off by means of a safety integrity level (SIL). The user is responsible for securing the pump against overpressure on the process side if the user considers this to be necessary. Quattroflow recommends the use of an external safety pressure shut-off.

NOTE

If the measurement frequency is too slow, and/or the filter time of the pressure sensor is too high, there is a risk that the pressure shut-off will react too slowly and the pump or the process system could be damaged by excess pressure.

It is recommended that the pressure sensor be installed as close to the outlet of the feed chamber as possible so that the sensor can quickly detect overpressure.

Depending on the type and design of the pressure sensor and the pump chamber, it must be ensured that the process connection to the feed chamber is not loaded with too much weight. In this case, the pressure sensor should be supported in order to prevent damage to the feed chamber.

The sensor should work at as high a measurement frequency (sample rate) as possible, without a filter time, in order to detect overpressure and stop the pump as quickly as possible. The measurement frequency should be at least 1 Hz. The user is responsible for the final setup and configuration of the pressure shut-off.

The pressure shut-off can be implemented with an analog and/or digital alarm, and the activation of the alarm is based on the normal procedure as described in sections 11.1.1 and 11.1.2.

11.2 Sensor alarms and sensor monitoring

11.2.1 Sensor-Alarm analog inputs

The sensor monitoring checks whether the current signals of the analog inputs (AIN1, AIN2, AIN3) are in the correct measuring range. The alarm is triggered when the current signal is below or above the alarm limits (see Table 39).

Type Analog-Input	Low Alarm limit	High Alarm limit
Standard Analog-Input	< 3,6 mA	> 21,0 mA
Analog-Input for em-tec (option)	< 1,0 mA	> 21,0 mA
Analog- Input for PendoTECH (option)	< 1,6 mA	> 22,0 mA

Table 39 Sensor-Alarm; Alarm limits

NOTE

Analog-input AI4 (voltage input) has not sensor monitoring due to technical reasons

Function in case of a sensor alarm

- During pump operation → pump is stopped immediately + error message
- Start of the pump → pump cannot be started + error message

The error message contains information about the source (analog input) and the cause of the alarm:



Picture 71 Sensor alarm (example)

Activation of the sensor monitoring

As soon as a process alarm for an analog input has been activated by the user, the corresponding sensor and signal input is permanently monitored in all operating modes.

In the operating modes **Flow Control** and **Pressure Control**, the correspondingly assigned analog inputs are permanently monitored, even if no process alarm is activated by the user.

Without a correctly functioning sensor, these modes cannot be started and a sensor alarm is shown.

The monitoring is based on the selected analog inputs for the flow and pressure sensor in the settings:

MENU > Settings > Sensor Mapping

Possible causes for a sensor alarm

- No sensor connected or sensor defective
- The cabling of the sensor is not correct
- The sensor signal does not match the configuration in Q-Control
- Too high current could be caused by a short circuit

If the alarm occurs on a pump with the integrated em-tec and/or PendoTECH option, the instructions in the respective chapter for troubleshooting should be observed:

em-tec: 9.1.8

PendoTECH: 9.2.7

11.2.2 Sensor-Alarm Digital inputs

The sensor monitoring checks whether the logic (0/1 or positive / negative) of the digital inputs changes and whether it corresponds to the logic set by the user. The monitoring applies to all digital inputs (DIN1, DIN2, DIN3).

How it works in the event of a sensor alarm

- While the pump is running -> the pump stops immediately + error message
- Starting the pump -> Pump cannot be started + error message

The same error message appears as with an activated digital process alarm. The source (digital input) for the alarm is named:



Picture 72 Error message for sensor alarm digital (example)

Activation of the sensor monitoring

As soon as a process alarm for a digital input has been activated by the user, the corresponding sensor and signal input is monitored in all operating modes.

Condition for a sensor alarm

Logic change

The signal changes its logic (0/1 or positive / negative)

A logic change can be triggered by the following causes:

- No sensor connected or sensor defective
- The cabling of the sensor is not correct
- The signal or the wiring of the sensor (NC or NO) does not match the configuration in Q-Control (**Settings > DIN inverted**)

NOTE

The Q-Control software cannot recognize whether the logic change was triggered by an error condition (e.g. cable break) or by a process alarm defined by the user. The same error message appears in both cases. See also chapter 11.1.2.

12 Integrated functions

This section describes other integrated functions of the Q-Control that can be used in one or more operating modes.

These functions cannot be set from the **Operating mode** window, but instead are based on the parameters selected under **Settings**.

12.1 Totalizer

The **Manual RPM** and **Manual flow** modes include a totalizer function that integrates the volume flow rate values. See also sections 10.1.4 and 10.2.4.

Conditions for display in the main window:

- **MENU > Settings > Manual modes > Totalizer > Yes**
- The **Manual RPM** or **Manual flow** mode is used.

The totalizer can be reset or zeroed out in the settings:

- **MENU > Settings > Manual modes > Reset > OK > Confirm popup**

The volume flow rate can be determined by an internal calculation or from the sensor values.

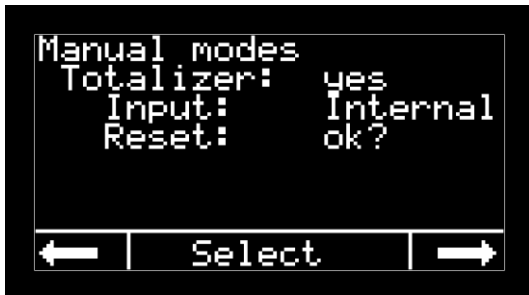

Picture 73 Totalizer; configuration (example)

12.1.1 Internal

Internal calculation of the volume flow rate using the current speed setting [RPM] and the displacement volume (calibration factor).

Conditions for use:

- **MENU > Settings > Manual modes > Input > Internal**
- A reasonable value must be set for the calibration factor:
MENU > Settings > Parameter 1 > Cal [ml/rev]

For more information on setting and optimizing the calibration factor, see Section 12.2.

NOTE

The feed chamber must be completely filled and bled in order to use the internal calculation of the transported volume.

12.1.2 Sensor

Evaluating the volume flow rate with a connected flow sensor.

Conditions for use:

- **MENU > Settings > Manual modes > Input > Sensor**
- The flow sensor must be connected to **Analog input 1...4**.
- The flow sensor must have parameters set:
MENU > Settings > Analog input 1...4
- The flow sensor must be assigned as the master sensor:
MENU > Settings > Sensor mapping > Flow

12.2 Calibration factor / displacement volume (Cal)

The calibration factor is the displacement volume, indicated in the unit milliliters per revolution of the pump shaft [ml/rev].

The calibration factor can be set in the following menu:

MENU > Settings > Parameter 1 > Cal [ml/rev]

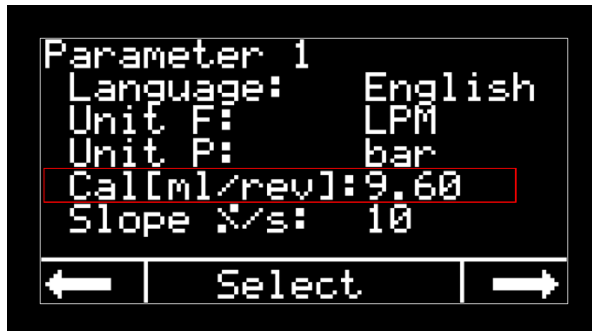

Picture 74 Parameter Cal (example)

The calibration factor is used for the following operating modes and functions:

- Manual flow
- Dispensing
- Totalizer with internal calculation
- USB logging of calculated volume flow

Because the Quattroflow pump is a diaphragm pump (displacement pump), the displacement volume remains nearly constant over the range of speed and is only slightly dependent on the backpressure. Using the calibration factor and the speed, the volume flow can be determined relatively precisely:

$$\text{Volumenstrom [LPM]} = \text{Kalibrierfaktor} \left[\frac{\text{ml}}{\text{rev}} \right] * \frac{\text{Drehzahl [UPM]}}{1000}$$

$$\text{Flow rate [LPH]} = \text{Calibration Factor} \left[\frac{\text{ml}}{\text{rev}} \right] * \text{Pump Speed [RPM]} * 0,06$$

The actual displaced volume depends on the following conditions:

- Backpressure
- Age and condition of the elastomers
- Medium
- Temperature
- Pump model (size, eccentric shaft, drive)

To obtain the greatest possible accuracy when converting between speed and volume flow, the displacement volume can be determined on a process basis. This calibration should be performed with the same process and system properties as will be used in the actual process.

Please note that the Quattroflow feed chamber should be completely bled in order to obtain the highest possible accuracy and repeatability. More information on this topic can be found in the general Operation Manual and in the "Installation & Operation Guide."

12.2.1 Determining the calibration factor

The value for the displacement volume is indicated in the technical data sheets for each Quattroflow pump. The value is indicated with the unit [ml/rev] (volume in milliliters per revolution). This value is defined as standard for an open pump outlet with no backpressure (relative pressure approximately 0 bar).

If greater accuracy is required, then the customer has the option of setting the displacement volume per revolution himself under defined process conditions. To do so, it is necessary to measure the absolute volume transported by the pump in a particular span of time.

The calibration procedure is as follows:

1. Fill and bleed the pump completely in manual mode.
2. Make the following settings in the filling parameters:
 - a. Volume: desired filling volume (e.g., 1000 ml) = V_{spec}
 - b. Number of 1
 - c. Time: desired time (e.g. 10 sec)
 - d. Pause: not relevant (e.g. 1 sec)
3. Change to dispense mode
4. Now place a sufficiently large container (taking the empty weight beforehand if needed) under the dispensing point and start the dispensing process by pressing the start button.
5. Determine the transported volume (V_{act}), using a scale (considering the density), or with a measuring cylinder.
6. Determining the calibration factor:

$$Cal_{new} = \frac{V_{act}}{V_{spec}} \cdot Cal_{old}$$

Example:

Desired dispensing volume $V_{\text{spec}} = 500 \text{ ml}$

Current calibration factor $\text{Cal}_{\text{old}} = 9.6 \text{ ml/rev}$

Actual dispensed volume determined $V_{\text{act}} = 495 \text{ ml}$

Calculation for the new calibration factor:

$$\text{Cal}_{\text{new}} = \frac{495\text{ml}}{500\text{ml}} \cdot 9,6 \frac{\text{ml}}{\text{rev}} = \mathbf{9,41} \frac{\text{ml}}{\text{rev}}$$

The new calibration factor is then entered in the parameter settings. If necessary, this process can be repeated two or three times in succession in order to increase the accuracy.

If changes are made to the process, the pump or the system, the calibration factor should be determined again.

12.2.2 Standard values

The displacement volumes for each pump model are saved in Q-Control at the factory. These values are standard values for the following standard conditions:

- Water
- Room temperature
- New elastomers / new single-use chamber
- Open outlet (» 0 bar relative pressure)
- Fully primed pump

The standard values for each pump model can be found in this Operation Manual in section 18.2.

12.2.3 Influence of the calibration factor on the dispensing operating mode

As described in section 10.4, the calibration factor flows into the dynamic limit calculation for the dispensing settings. If changes to the calibration factor affect parameter setting for dispensing the following message appears:

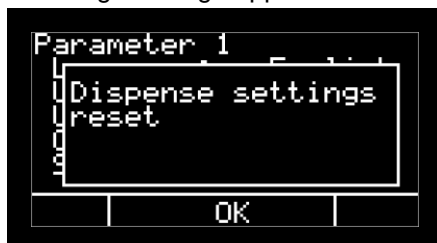

Picture 75 Message Dispense settings reset

The parameters for dispensing are also automatically adapted to the new calibration factor:

- The previous setting for the parameter **Run [s]** is retained
- The previous setting for the parameter **Wait [s]** is retained
- The parameter **Volume** is re-calculated on the basis of a pump speed of 100 RPM and set automatically

12.3 Maximum Values (user limits)

The user can set own various maximum values in order to operate the pump only under particular operating and process conditions. These maximum values are used in various operating modes and limit the target values that can be set during operation.

NOTE

The maximum values are not process alarms. When the maximum value is reached, the pump does not shut off automatically.

Make the settings in the following menu:

MENU > Setting > Max values

Parameter	Description
UPM	<p>Maximum pump speed The parameters are used in all operating modes.</p> <p>The maximum speed defined by the manufacturer can be reduced by the user, but not increased above the maximum specified by the manufacturer.</p> <p>Unit: [RPM]</p>
Max F	<p>Maximum volume flow Used in the following operating modes:</p> <ul style="list-style-type: none"> ▪ Manual flow ▪ Flow control (maximum setpoint setting, SP) <p>Unit: MENU > Settings > Parameter 1 > Unit F</p> <p>NOTE The parameter Max F is used only if it is less than the maximum measurement value of the flow sensor: MENU > Settings > Analog input 1...4 > Max value</p>
Max P	<p>Maximum pressure Used in the following operating modes:</p> <ul style="list-style-type: none"> ▪ Pressure control (maximum setpoint setting, SP) <p>Unit: MENU > Settings > Parameter 1 > Unit P</p> <p>NOTE The parameter Max P is used only if it is less than the maximum measured value of the pressure sensor: MENU > Settings > Analog input 1...4 > Max value</p>

Table 40 Max Values; configuration

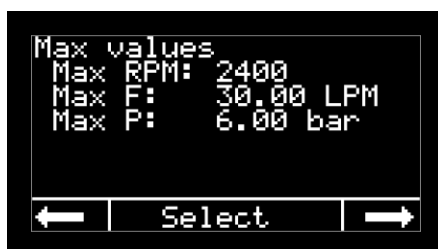

Picture 76 Maximum values; configuration (example)

12.3.1 Influence of Max RPM in the Manual flow operating mode

Q-Control calculates the maximum speed from the following two parameters:

MENU > Settings > Maximum values > Max F

MENU > Settings > Parameter 1 > Cal [ml/rev]

This calculated value for the speed is compared with the set value for **Max RPM**. The smaller of the values for the maximum speed setting and maximum flow setting is used.

Example 1 for a QF1200

Parameter settings:

Maximum values:

Max. UPM: 1500 UPM

Max. F: 10.0 LPM

Parameter 1:

Cal [ml/rev] 9.80 ml/rev

The maximum speed is calculated from the values **Max F** and **Cal**:

$$\frac{10 \text{ LPM} * 1000}{9,6 \text{ ml/rev}} = 1020 \text{ RPM}$$

Because the calculated speed in this case is less than the value for **Max RPM** (1500 RPM), a maximum speed of 1020 RPM is used. In order to increase the speed, the value for **Max F** must be increased.

Example 2 for a QF1200

Parameter settings:

Maximum values:

Max. UPM: 1500 UPM

Max. F: 20.0 LPM

Parameter 1:

Cal [ml/rev] 9.80 ml/rev

The maximum speed is calculated from the values **Max F** and **Cal**:

$$\frac{20 \text{ LPM} * 1000}{9,6 \text{ ml/rev}} = 2041 \text{ RPM}$$

In this example, the calculated speed is greater than the value for **Max RPM** (1500 RPM). Therefore a maximum speed of 1500 RPM is used. In order to increase the speed, the value for **Max RPM** must be increased.

12.3.2 Influence of the parameter Max RPM on the Dispensing operating mode

The maximum value for the speed, **Max RPM** is used in the dynamic calculation of limit values in the menu **Dispensing**.

If the currently set values for **Dispensing** cannot be reached with the newly set value for Max RPM, the parameters for the dosing settings are reset and the following message appears:

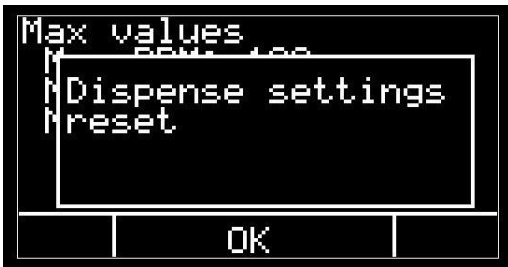

Picture 77 Message Check dispense settings

The settings for **Dispensing** can then be adjusted within the new limits. For more information, see section 10.4.

12.4 Slope (motor acceleration)

The function *is used* to set the motor acceleration individually. The smaller the value for the slope, the slower the motor accelerates. The slope influences the positive and negative acceleration of the motor.

Make the settings in the following menu:

MENU > Settings > Parameter 1 > Slope [%/s]



Picture 78 Parameter 1, Slope (example)

The parameter *Slope* is used in all operating modes:

- Manual RPM
- Manual flow
- External RPM
- Dispense
- Flow control
- Pressure control

The slope influences the motor in the following situations:

- **START**
Rise time from stopped state (0 RPM) to the setpoint speed.
This also applies to operating modes in which the specified speed is calculated from a different specified value (*Manual flow, Flow control, Pressure control, External control*)
- **Speed changes**
A manual change to the setpoint value while the pump is running.
Automated speed change (flow and pressure control).
A speed change in External mode.

NOTE

The parameter **Slope** has no influence on the **STOP** function. The pump stops immediately, regardless of whether the pump is stopped manually, automatically (e.g. by an alarm), or by an external signal.

NOTE

Please see the notes on the influence of the **Slope** on the flow and pressure control modes and the autotune functions. See section 10.5.3.

The upper limit that can be set by the user for the **Slope** depends on the pump model and is defined by the manufacturer. This values cannot be exceeded by the user.

The parameter **Slope** has the unit [%/s] and always refers to the maximum pump speed defined by the manufacturer, which cannot be changed by the user. The change rate is defined in percent per second.

The maximum speed set by the customer (**Settings > Max values > Max RPM**) is not used when calculating the slope.

Example 1: Fast slope

QF150 pump with a maximum speed of 3000 RPM

Slope [%/s]: 50

$$3000 \text{ UPM} * \frac{0,5}{s} = 1500 \frac{\text{UPM}}{s}$$

→ The motor changes its speed at a rate of 1500 RPM per second.

→ From 0 RPM to 3000 RPM, the pump requires a time of 2.0 seconds.

Example illustration of a fast slope, without absolute values:

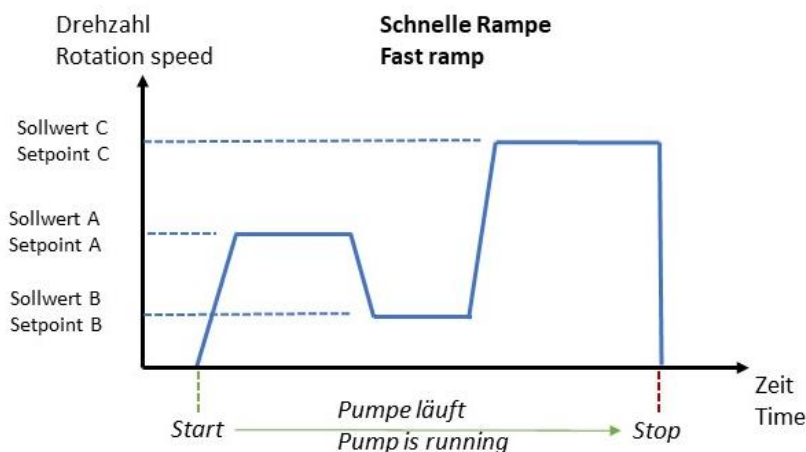

Picture 79 Example for a fast slope

Example 2: Slow slope

QF150 pump with a maximum speed of 3000 RPM

Slope [%/s]: 20

$$3000 \text{ UPM} * \frac{0,2}{s} = 600 \frac{\text{UPM}}{s}$$

- The motor changes its speed at a rate of 600 RPM per second.
- From 0 RPM to 3000 RPM, the pump requires a time of 5 seconds.

Example illustration of a slow slope, without absolute values:

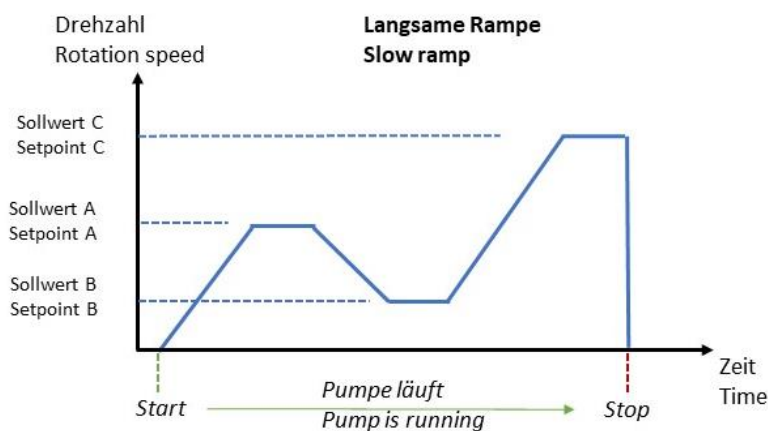

Picture 80 Example for a slow slope

Please note that the display always shows the setpoint setting (RPM, flow, pressure). The actual speed of the motor, particularly for a slow slope setting, can vary significantly from this value before the pump reaches the setpoint value. If the setpoint is modified while the speed is changing, the pump runs to the new setpoint immediately.

A slow slope can be advantageous, for example, if a system is to be filled with medium at a slow rate, or if a filter needs to be brought up to speed slowly. Rapid changes in volume flow rate and the resulting changes in pressure can thus be avoided. As a general rule, larger Quattroflow pumps (e.g., QF2500, QF4400) should be run up more slowly in order to reduce the load on the pump and the system.

12.5 External start/stop

All operating modes provide the ability to start or stop the pump via an external control system. An analog signal (with threshold value) or a digital signal can be used for this.

WARNING

It must be ensured that the pump is operated safely when the pump is started or stopped externally. The pump or the system should be automatically protected against overpressure in this case.

WARNING

If the **Keylock** function is activated, the pump cannot be stopped via the keypad. In order to stop the pump at the device, the main switch must be pressed and the power supply cut off completely.

Conditions for use:

- Define signal source
MENU > Setting > External control > Start/Stop
- The signal source must be connected to the pump.

Make the settings in the following menu:

MENU > Setting > External control

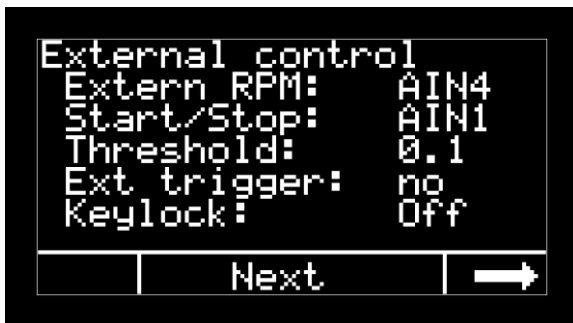

Picture 81 External control; configuration (example)

Parameter	Description
External RPM	For external speed setting via analog-signal See Section 10.3
Start/Stop	<p>Select the signal source with which the pump is to be started and stopped externally.</p> <p>The following conditions apply to the selection of the signal source:</p> <ul style="list-style-type: none"> ▪ The signal source must not be assigned to an alarm at the same time. ▪ The signal source must not be assigned to a master sensor (sensor assignment). <p>If any of the above conditions are not met, you will receive the following error message:</p>  <p><i>Picture 82 External start/stop; error message</i></p> <p>In this case, please select another signal source for the external start/stop signal.</p>
Threshold	Only applicable to analog signals for the parameter start/stop. Determines the analog raw value to be executed upon start/stop.
Ext. Trigger	See next section below, 12.5.1
Keylock	Activates the keylock for the softkeys. The pump cannot be stopped from the keypad. In order to stop the pump manually at the device, the main power switch must be pressed and the power supply cut off completely.

Table 41 External Start/Stop; configuration

12.5.1 Function of the parameter External Trigger

OFF for analog signal

Start: Signal \geq threshold value

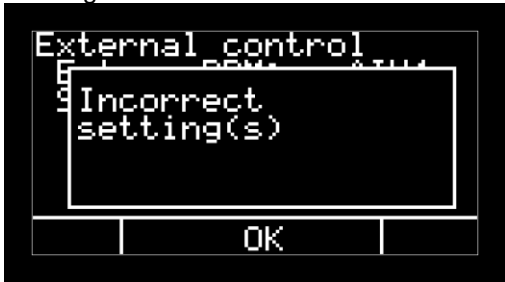
Stop: Signal $<$ threshold value

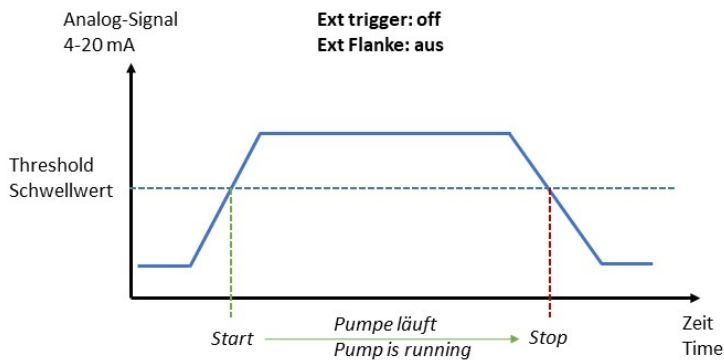

Picture 83 External Start/Stop, Ext. trigger OFF, analog

OFF for digital signal

Start: Signal changes its logic (rising flank)

Stop: Signal changes its logic (falling flank)

Note: Function depends on the logic setting (Settings > DIN inverted)

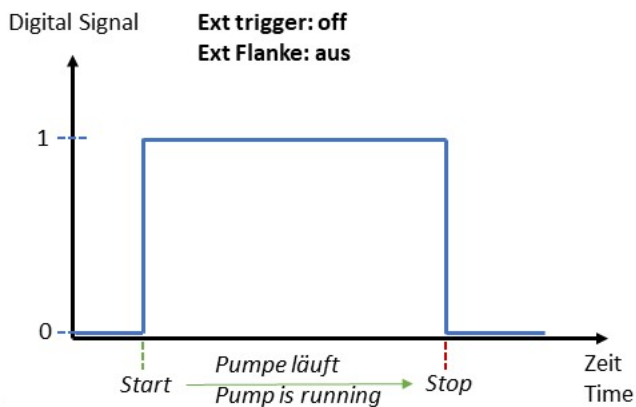

Picture 84 External Start/Stop, Ext. trigger OFF, digital

ON for analog signal

Start: Signal \geq threshold value

Stop: Signal $<$ threshold value \rightarrow Signal \geq threshold value

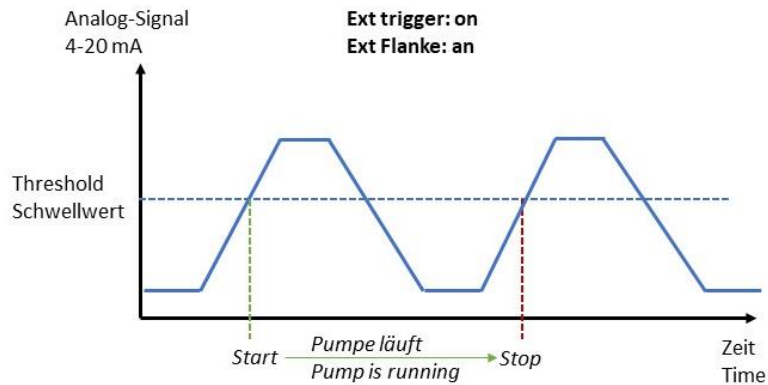

Picture 85 External Start/Stop, Ext. trigger ON, analog

ON for digital signal

The pump starts/stops at the rising flank of the digital signal.

For use, for example, when a foot pedal is used for start/stop. The pedal does not need to be held down in order for the pump to run.

Note: Function depends on the logic setting (Settings > DIN inverted)

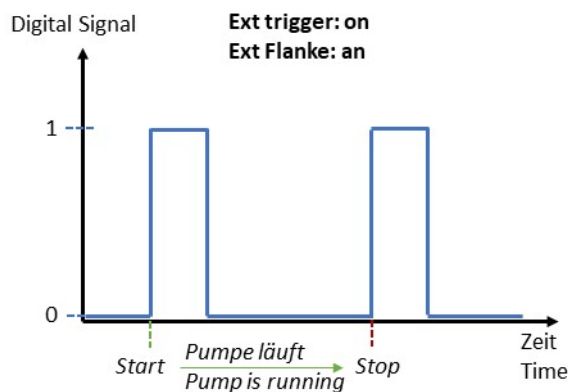

Picture 86 External Start/Stop, Ext. trigger ON, digital

12.5.2 Function of External start/stop in all operating modes

Setting / Operating state	Depiction in main window / Function
Keylock OFF	
External start/stop is activated + The pump was started by an external signal and is running	The middle button is labeled as: EXTERNAL STOP The pump can be stopped by means of the EXTERNAL STOP button. The two buttons + - on the display can still be used (except for External RPM mode)
External start/stop is activated + The pump is stopped	The middle button is labeled as: START The pump can be started manually by means of the middle START button. The external control for start/stop is deactivated as long as the pump is running. The external signal is not used until STOP is pressed on the display. NOTE If the pump has received the external start signal during this time, then STOP must first be pressed on the display, and then EXTERNAL STOP , in order to stop the pump manually. The two buttons + - on the display can still be used (except for External RPM mode)
Keylock ON	
External start/stop is activated + Keylock is activated	The middle button is permanently labeled as: EXTERNAL The pump cannot be stopped or started manually by means of the EXTERNAL button. A popup message appears when the button is pressed.  <p style="text-align: center;"><i>Picture 87 External start/stop; message keylock</i></p> The two buttons + - on the display can still be used (except for External RPM mode)

Table 42 External Start/Stop; operation and display

12.6 Signal outputs

The Q-Control has two signal outputs that can be used optionally by the user.

12.6.1 Analog output (AO)

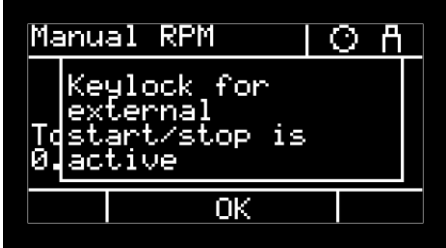
Make the settings in the following menu:

MENU > Setting > Analog output

Parameter	Description
Type	<p>Off Function is deactivated</p> <p>4-20 mA The calculated or set motor speed is output</p>

Table 43 Analog output; configuration

The conversion between the analog signal and the speed is based on linear scaling with the following minimum and maximum values:

Analog signal	Pump speed
4 mA	0 UPM Identical for all pump models
20 mA	Max. UPM Based on the particular pump model and cannot be changed by the user.

Table 44 Analog output; scaling

The maximum speeds defined by Quattroflow can be found in the corresponding data sheets for the pump model: www.Quattroflow.com

If the analog output is activated, but there is no cable connected to the pump (output is open), then the following error message appears:

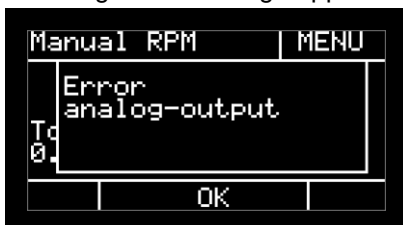

Picture 88 Error message analog output

The pump cannot be started until the signal cable is correctly connected, or the analog output has been deactivated in the settings.

12.6.2 Digital output (DO)

The digital output of the Q-Control cannot be configured in the settings. As standard, the digital output is directly connected to the drive and indicates the following status:

Digital signal	Meaning
1	Motor / drive has no errors and is ready
0	Motor / drive is not ready

Table 45 Digital output; signals

In order to use the digital output, the connection on the back side of the pump must be used.

NOTE

The digital output does not have a broken wire detection or sensor monitor in the Q-Control.

12.7 Screensaver

The Q-Control display has a screen saver. The user can set a time interval before the screen saver is active.

Make the settings in the following menu:

MENU > Setting > Screensaver

The screen saver is active in all operating modes, regardless of whether the pump is stopped or started. When activated, the screen saver shows the time of day and the operating state of the pump:

Pump stopped:

Time

Off

Pump is running:

Time

Current speed in RPM

The screen saver can be stopped by pressing any key. The main window is then displayed.

12.8 Display of the analog-input values during operation

This function was implemented from Software version 02.XX.XX

When the pump is running, the values of all four analog-inputs can be displayed in all operation modes. For this display the key **D** has to be held down.

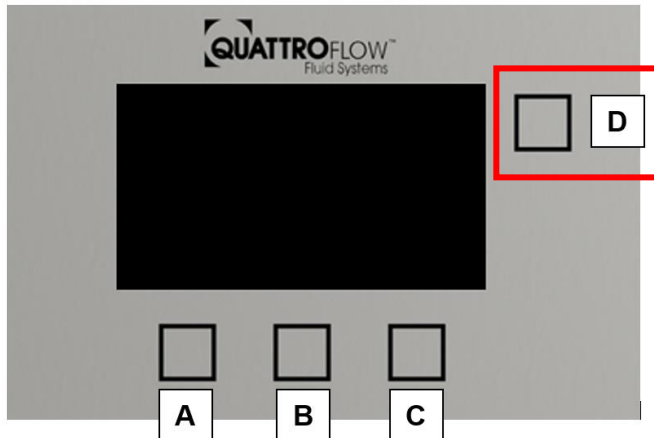

Picture 89 Control panel; display values

The lower three buttons **A B C** can be operated during this time. The pump can therefore be stopped at any time, even while the popup is displayed.

As long as the key is held down, a popup with the following lines is displayed in the main window:

AIN1	Numeric value	Unit
AIN2	Numeric value	Unit
AIN3	Numeric value	Unit
AIN4	Numeric value	Unit

Picture 90 Display for analog input values

The displayed units for flow and pressure signals are used from the following parameter settings:

MENU > Settings > Parameter 1 > Unit F

MENU > Settings > Parameter 1 > Unit P

If an analog input is set to type **RSS**, it has the fixed unit percentage [%].

To display the raw values for current [**mA**] for AIN1, AIN2, AIN3 or for voltage [**V**] for AIN4, the respective analog input can be set to type **Raw**.

13 USB Logging

13.1 General information

Q-Control has an option for data logging to a USB stick.

NOTE

When the USB stick is connected to the pump, the IP protection level specified in the Q-Control data sheet is not met. The user must ensure that no dust or liquids get into the USB port.

Depending on the type of pump, the USB stick is connected at the rear or front of the pump. When the USB stick has been connected and detected, the following message appears for a few seconds:



Picture 91 Message USB connected

NOTE

The USB stick must not be connected or removed while the pump is running and the following symbol is displayed in the top right corner of the main window:



Picture 92 USB logging active

This could damage the data on the USB stick!

13.2 Configuration

Make the settings in the following menu:

MENU > Setting > USB logging



Parameter	Description
Active	<p>On: USB logging is activated.</p> <p>During logging, the following symbol is displayed at the top right of the main window:</p>   <p><i>Picture 93 USB logging active; symbol</i></p> <p>Data is logged whenever the pump is running. The data set is saved when the STOP button is pressed or an alarm stops the pump. A new file is created for every run bounded by a START / STOP.</p>
Decimal	<p>Select the decimal symbol</p> <p>• ,</p>
Interval [s]	<p>Logging interval in seconds Fastest logging: 1 second</p>

Table 46 USB logging; configuration

13.3 Recording format

The file is saved in the main folder on the USB stick in CSV format and is named according to the following schema:

QF_YYYYMMDD_HHMMSS.CSV

YYYYMMDD: Date of data logging

HHMMSS: Logging start time

The file can be opened in conventional spreadsheet programs, such as Microsoft Excel. Depending on the settings in Q-Control and the spreadsheet program, it may be necessary to use the “Import data” function to open the file. A semicolon (;) is used as the standard separator between individual values.

Alternatively, the CSV file can be opened in a program such as Microsoft Editor in order to read the raw data.

The raw data is shown in the CSV file according to the following scheme. The first line is a header with values and units in English:

Date [YYYY-MM-DD]	Time [HH:MM:SS]	Rotation speed [UPM]	Flow Calculated [dyn. unit]
-----------------------------	---------------------------	--------------------------------	---------------------------------------



AI1 dyn. type [dyn. unit]	AI2 dyn. type [dyn. unit]	AI3 dyn. type [dyn. unit]	AI4 dyn. type [dyn. unit]
-------------------------------------	-------------------------------------	-------------------------------------	-------------------------------------



AO [mA]	DI1	DI2	DI3
----------------	------------	------------	------------



Alarm AI1	Alarm AI2	Alarm AI3	Alarm AI4
------------------	------------------	------------------	------------------



Alarm DI1	Alarm DI2	Alarm DI3
------------------	------------------	------------------

Date and time

Can be set in the following menu:

MENU > Settings > Time and Date

These settings are only used for the USB logging.

Rotation speed

Depending on the pump type, either the actual pump speed (encoder) or the calculated speed is logged.

The speed is always shown in the unit [RPM].

Flow Calculated

Depending on the pump type, the flow rate is calculated either based on the actual pump speed (encoder) or based on the calculated speed and displacement volume.

The unit of the logged volume flow rate is taken from the following parameters and is shown dynamically in the header line:

MENU > Settings > Parameter 1 > Unit F

AI1...AI4

The type (raw value, flow, pressure) is taken dynamically from the following settings and displayed in the header line:

MENU > Settings > Analog input 1...4 > Type

The unit is taken from the following parameters and changes dynamically in the header line depending on the type selected:

MENU > Settings > Parameter 1 > Unit F / Unit P

AO

Analog-Output: Returns the actual speed as an analog current signal in the unit [mA].

Depending on the pump type, either the actual pump speed (encoder) or the calculated speed is logged.

DI

Digital input: shown as "0" or "1", depending on the logic setting.

Alarms

Shown as "0" as long as the pump is running. If the alarm has tripped, this value is shown as "1".

Logging then stops automatically, as the pump has been stopped by the alarm.

For digital alarms, the 0/1 can be reversed, depending on the logic setting.

Recoding of invalid measuring values

If invalid measuring values are detected, that are outside the measuring range, dashes are shown in the display in operation modes **Manual RPM**, **Flow control** and **Pressure control**.

If USB recording is active, the values are recorded as **zeros (0)**. This applies to all operating modes and to all analog inputs, even if these inputs are not shown on the display.



Picture 94 USB logging; invalid measuring values

14 Saving and loading configuration (parameterization)

14.1 General information

The current configuration (parameter settings) can be saved to an USB stick by the user (config export). A configuration can also be loaded to Q-Control from an USB stick (config import).

This function can be used, for example, to transfer the configuration from one pump to other pumps of the same construction. These pumps then no longer have to be set up manually, which saves time. It is also possible to use one pump for different applications. Depending on the application and required sensors, the configuration of the pump can be changed in a short time. A separate configuration can be saved on the USB stick for each application.

NOTE

The USB stick must not be removed while the parameter file is being loaded or saved. This could damage the data and settings.

NOTE

Loading a configuration overwrites the current, local settings in Q-Control. If there is no backup, this configuration cannot be restored.

NOTE

When the USB stick is connected to the pump, the IP protection level specified in the Q-Control data sheet is not met. The user must ensure that no dust or liquids get into the USB port.

14.2 Use

The USB stick is connected at the rear or front of the pump. When the USB stick has been connected and detected, the following message appears for a few seconds:



Picture 95 Message USB connected

Perform the actions in the following menu:

MENU > Setting > Configuration

Parameter	Description
USB write	<p>Function: Config file will be exported to an USB-stick</p> <ul style="list-style-type: none"> > OK confirm > Press YES to confirm the popup <p>Another message indicates that the file was successfully saved to the USB stick:</p> <div style="text-align: center;">  </div> <p><i>Picture 96 Message; configuration is written to USB</i></p> <p>The configuration file is saved in the main folder of the USB stick and always has the following file name: QControlConfig.bin</p> <p>NOTE Writing a configuration overwrites the file on the USB stick if a configuration file is already available. Make a backup copy of the file beforehand or change the file name on the USB stick if you do not want to overwrite the existing file.</p>

Parameter	Description
USB load	<p>Function: Config file will be imported from an USB-stick</p> <p>> OK confirm > Press YES to confirm the popup</p> <p>Another message indicates that the file was successfully loaded from the USB stick:</p>  <p><i>Picture 97 Message; configuration is loaded from USB</i></p> <p>NOTE The configuration file must be saved in the main folder of the USB stick and have the following file name: QControlConfig.bin</p>

Table 47 Write and load of the configuration

14.3 Compatibility of the configuration

If a previously saved configuration file is to be used for several pumps with different firmware versions, the following must be observed:

The firmware version installed on the pump that is used to import the configuration must be the same or newer than the firmware version that was used to export the configuration.

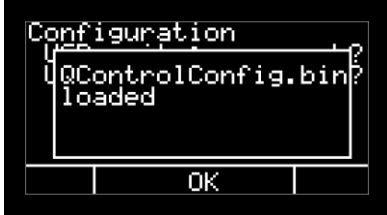
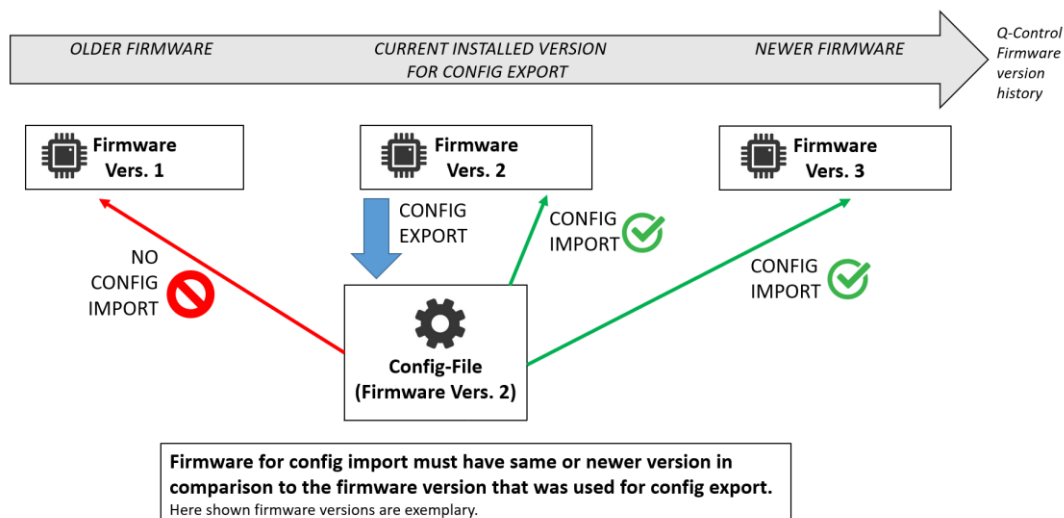

Picture 98 Compatibility of the configuration (firmware versions are exemplary)

As of firmware version 02.XX.XX, the compatibility of the config file is checked automatically when the configuration is loaded.

If the previously listed condition is not met, loading is aborted, and the following error message appears:

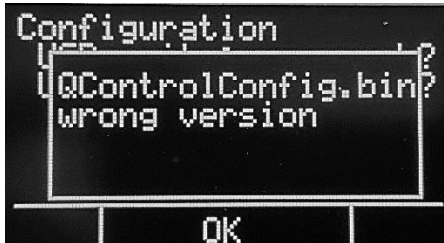

Picture 99 Error message during configuration loading

The error message appears if the configuration was created with a newer firmware version compared to the firmware version with which the configuration is to be loaded.

In order to be able to load the configuration, a firmware update must be carried out beforehand.

Please contact your Quattroflow sales partner or the Quattroflow service team.

Further information on the firmware update can be found in section 15.

NOTE

Configuration files created with firmware version 02.XX.XX or newer must not be used for pumps with firmware versions 01.XX.XX. There is no automatic compatibility check in these versions. Please check the installed firmware version in the settings and, if necessary, update the firmware to version 02.XX.XX or newer.

14.4 Factory Settings and Factory Reset

This function was implemented from Software version 02.XX.XX

If necessary, the user can reset the pump to the Quattroflow factory settings. The actions are carried out in the following menu:

MENU > Settings > Configuration > Factory Reset

The factory settings can be found in chapters 18.2 and 18.3. The factory settings depend on the pump type and the eccentric shaft that was installed on delivery. All parameters in all levels (free level, supervisor level, manufacturer level) are reset.

Note for Firmware-Update

After a firmware update, the correct Quattroflow standard configuration must be loaded once so that the **Factory Reset** function can continue to be used correctly. For further information see chapter 15.3

Note for conversation between QF30QCON / QF150QCON

For more information on the **Factory Reset** function when converting between QF30QCON and QF150QCON, see Chapter 17.3

15 Firmware update (Software)

The user can perform a firmware update if the manufacturer has provided new firmware versions. The firmware can be updated via an USB stick.

15.1 Important Information about Firmware Update

The firmware file must be saved in the main folder on the USB stick and must have the following filename:

image.bin

If the file provided by the manufacturer does not have this name, rename the file.

The versions of the firmware are named by default according to an ascending number system. The currently installed version can be viewed in the settings:

MENU > Settings > Versions

NOTE

The firmware may only be updated to a newer version. Downgrading to an older version can lead to problems with the software and functionality of the Q-Control.

NOTE

Only applicable for Firmware-Updates from Version 01.XX.XX to 02.XX.XX or newer:

After a firmware update, the standard configuration (parameters) of Quattroflow must be loaded once.

The user configuration will be overwritten during this procedure.

NOTE

While the firmware is being loaded, the power supply to the pump must be maintained and the USB stick must not be removed.

This could otherwise damage the data and settings.

NOTE

When the USB stick is connected to the pump, the IP protection level specified in the Q-Control data sheet is not met. The user must ensure that no dust or liquids get into the USB port.

15.2 Procedure for Firmware Update

- The USB stick is connected at the rear or front of the pump. When the USB stick has been connected and detected, the following message appears for a few seconds:



Picture 100 Message USB connected

- Shut off the pump at the main switch (power off)
- Make sure that the USB stick is connected correctly.
- Press and hold the three bottom buttons on the pump display at the same time

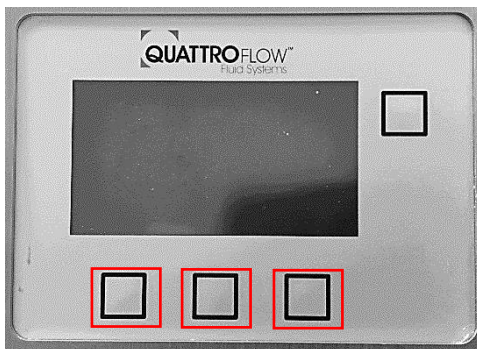

Picture 101 Starting Firmware update

- While holding the buttons, switch on the pump at the main switch (power on). The first line is displayed for the **bootloader** with the appropriate version. Now release the three buttons.
- Additional lines appear, as shown in the following example illustration:



Picture 102 Completed Firmware update

- Wait until the message **Press key to start** appears. This step may take a few seconds. During this time, do not remove the USB stick and do not turn off the pump.
- Press any key on the display. The main window is now displayed.

15.3 Loading of Standard-Configuration (only for FW 01.XX.XX)

The procedure in this chapter is only required for Firmware-Updates from Version 01.XX.XX to 02.XX.XX or newer.

In case the firmware is updated from version 02.XX.XX to a newer version, the correct standard-configuration is already stored in the Q-Control software.

Instantly after a firmware update, the standard configuration (parameters) must be loaded once for the respective pump type so that these standard parameters are saved as Factory default.

In case an existing QF30QCON pump is updated from FW version 01.XX.XX to 02.XX.XX or newer, the standard-configuration for max. motor speed 1000 RPM must be loaded!

Make sure that the correct Quattroflow standard-config is loaded from the USB-stick and not a customer config, that was written to the USB-stick. All config files have the same file name. The correct configuration depends on the pump type and the built-in eccentric shaft.

See chapter 14 for more information about loading a configuration from USB-stick.

After successfully loading of the configuration, two messages appear that the parameters have been loaded and automatically saved as factory settings:

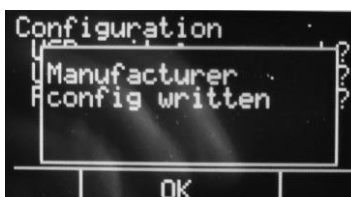
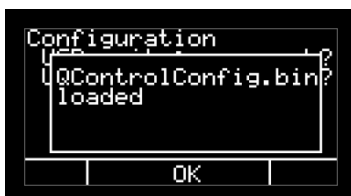

Picture 103 Message: Manufacturer config written

After the manufacture settings were automatically written, they cannot be changed by the user anymore.

16 RS485 Modbus

The pump with Q-Control has an RS485 Modbus Slave interface for externally controlling the pump or reading data. It can be configured in Modbus RTU or Modbus ASCII mode. This interface can be used to actuate the pump directly, for example by a process control system (PLC), or for external data logging.

16.1 Configuration

The Modbus protocol is configured in the menu under Modbus RS485. The standard values are listed below:

MENU > Settings > Modbus RS485

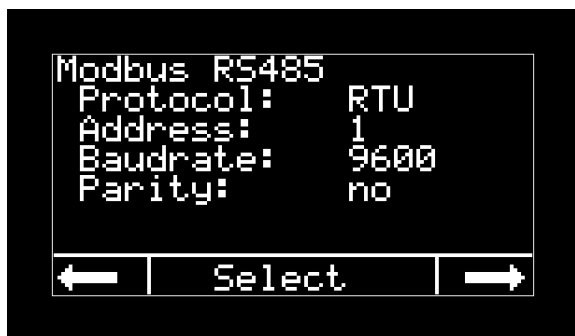

Picture 104 RS485 Modbus configuration

The standard values for the Modbus configuration can be found in chapter 18.2.

16.2 Modbus register

A listing of all Modbus register is available from Quattroflow on request.

16.3 Functional principle

This function was modified in Software version 02.XX.XX

All Modbus registers can be written while the pump is running. This means that the setpoints can be changed at any time in the various operating modes:

Manual RPM: Rotation speed

Manual flow: Flow rate

Pressure control: Setpoint for pressure

Flow control: Setpoint for flow rate

Additionally, the pump can be started and stopped with MODBUS signal in all operation modes.

17 Option: Conversation between QF30QCON / QF150QCON

17.1 Overview

QF30QCON and QF150QCON pumps are using the same drive unit with identical components. Therefore, the user has the possibility using the drive with two different pump heads. Thereto the user has to retrofit the pump.

The following table shows the possible options for modification by the user:

Pump type	Software-Version on delivery from the factory	Retrofitting by user
QF30QCON	02.XX.XX or newer	✓
QF150QCON	02.XX.XX or newer	✓
QF30QCON	01.XX.XX	✗ Please contact the Quattroflow Service Team
QF150QCON	01.XX.XX	✓ Software-Update by the user is required

17.2 Retrofitting by the user

The following steps must be carried out for a correct conversion.

NOTE

The QF30 pump head may be operated with a maximum motor speed of 1000 rpm. A modification must always include the adaptation of the standard parameters and must not be limited to the mechanical components.

1)

Check installed Software-Version of the Q-Control pump:

→ **MENU > Settings > Versions > Software**

If version 02.XX.XX or newer: go directly to point 2)

If version 01.XX.XX: a Software update to version 02.XX.XX (or newer) is required.

→ See chapter: 15 Firmware update (Software)

The file for a software update is available from Quattroflow on request.

2)

Loading the standard configuration (parameters) via USB stick for the corresponding pump type that is to be used after the conversion.

→ See chapter: 14 Saving and loading configuration (parameterization)

The files with the standard configuration are available from Quattroflow on request.

3)

Mechanical conversion of the pump head (ring drive / shaft-bearing-unit, pressure plate / adapter plate, pump chamber)

→ See standard operating instructions for QF30 and QF150 pumps

Explanations

The Quattroflow standard configuration only needs to be loaded once for the conversion. The parameters for the drive are set to the respective maximum speed. These parameters are not visible to the user and cannot be adjusted manually using the normal settings.

In addition, further parameters are correctly stored so that the pump corresponds to the standard factory settings of Quattroflow.

The user can then conventionally adjust the parameters (settings) as required and, if necessary, export and import them. These parameter files saved by the user are only to be used for the corresponding pump type.

The standard configuration must be loaded once for a renewed conversion.

17.3 Notes for Function Factory Reset

The Factory Reset function (from software version 02.XX.XX; see Chapter 14.4) cannot detect whether the pump is being operated with a QF30 or QF150 pump head. With a factory reset, the pump is always reset to the Quattroflow factory settings that were installed at the time of delivery or after a firmware update.

In the event of a factory reset that has loaded incorrect settings for the current pump type, the correct standard configuration for the corresponding pump type must be reloaded.

Pump type	Software-Version on delivery from the factory	Standard-Configuration for maximum motor-speed
QF30QCON	02.XX.XX or newer	3000 UPM
QF30QCON	01.XX.XX	1000 UPM

Table 48 Conversation between QF30QCON/QF150QCON; Standard-Configuration

18 Technical Documentation

This chapter lists the technical data for the Q-Control. The technical data and specifications for the complete pumps with Q-Control can be found in the standard operating instructions for the respective Quattroflow pump series.

18.1 Technical data Q-Control

18.1.1 Panel

Parameter	Value	Comment
Display Size	2,72"	
Type	OLED	
Voltage	24-48 VDC	
Min. current consumption	80-40 mA	No outputs, no USB, no RS485
Max. current consumption	150-75 mA	
Battery	3 V	Button cell type CR1220

Table 49 Technical data Q-Control (only control unit)

18.1.2 Specification connections

The following table shows the type and position of the connectors.

Port	Connector	QF30	QF150	QF1200	QF2500	QF4400 QF5K
X1	Phoenix Contact M12-Female, 8-pin *					Rear
X2	Phoenix Contact M12-Female, 8-pin *					Rear
X3	Pump type: standard Phoenix Contact M12-Female, 8-pin * Pump types: QCON... EP and QCON... -E 16-pin round connector for em-tec flow sensor					Rear
X4	Only for pump QCON...-EP and QCON...-P Phoenix Contact M12-Female, 8-pin Extension cable between pump and PendoTECH sensor is included					Rear
X5	Only for pumps: QCON... EP and QCON... -E RJ45 socket					Rear
RS485	Phoenix Contact M12-Female, 8-pin *					Rear
USB	USB 2.0 Type A					Rear
						Front

Table 50 Specification connectors

* The matching 8-pin M12 connector is included: PHOENIX CONTACT. Sensor / actuator connector, SACC-M12MS, item number 1513334

Max. Current load via ports X1 / X2 / X3: 800 mA (total)
Power supply for sensors

Variant-dependent port functions

Pump types based on pump coded (item numbers):

QCON Standard
QCON...-EP with integrated em-tec and PendoTECH Option
QCON...-E with integrated em-tec Option
QCON...-P with integrated PendoTECH Option

	Port X1	Port X2	Port X3	Port X4	Port X5
QCON	DI1 DI2 DI3 DO	AI1 AI3	AI2 AI4 AO	/	/
QCON...-EP	DI1 DI2 DI3 DO	AI3 AO	Socket for em-tec flow sensor	Socket for extension cable for PendoTECH pressure sensor	RJ45 socket for em-tec web interface
QCON...-E	DI1 DI2 DI3 DO	AI2 AI3 AO	Socket for em-tec flow sensor	/	RJ45 socket for em-tec web interface
QCON...-P	DI1 DI2 DI3 DO	AI3 AI4 AO	/	Socket for extension cable for PendoTECH pressure sensor für PendoTECH Drucksensor	/

Table 51 Variant-dependent port functions

For more information about Pin-allocation and wiring see chapter 5.8

18.1.3 Special operating elements (em-tec / PendoTECH option)

If the pump has an integrated em-tec and / or PendoTECH evaluation unit, the pump has built in special control elements for zeroing the sensors. Further information can be found in Sections 9.1.7 and 9.2.6

Pump types based on pump coded (item numbers):

- QCON Standard
- QCON...-EP with integrated em-tec and PendoTECH Option
- QCON...-E with integrated em-tec Option
- QCON...-P with integrated PendoTECH Option

	Qty and type	Marking	Position at Pump
QCON...-EP	2x buttons	ZERO FLOW SENSOR ZERO PRESSURE SENSOR	Front
QCON...-E	1x button	ZERO FLOW SENSOR	Front
QCON...-P	1x button	ZERO PRESSURE SENSOR	Front

Table 52 Special operating elements

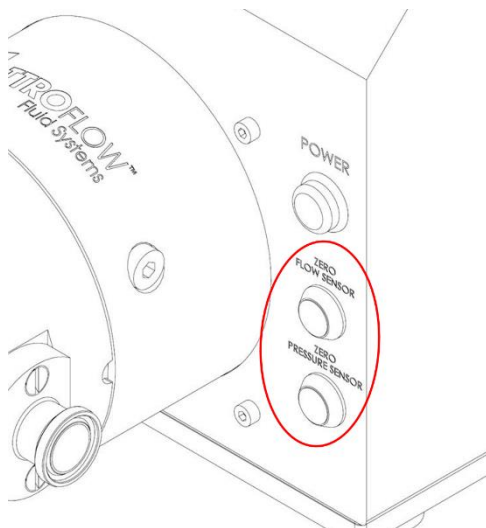

Picture 105 Special operating elements; Example for QF1200QCON...-EP

18.1.4 Inputs

Digital inputs (DI1, DI2, DI3)

Connection type	Min. voltage source	Max. voltage source
Floating contact Voltage source Internal "Pull Up" circuit	1 VDC	5 VDC

Table 53 Specification Digital inputs

Analog inputs

	Type of signal	Max. Output level	Working resistance	Resolution
AI1, AI2, AI3	4-20 mA	25 mA	200 Ω	16 bit
AI4	0-10 VDC	20 VDC		16 bit

Table 54 Specification Analog inputs

18.1.5 Outputs

Digital output

	Ready to run	= 1
Voltage	24V DC	Max. 30V DC
Current	50mA	

Table 55 Specification Digital output

Analog output

Type of signal	Resolution
4-20mA	16bit

Table 56 Specification Analog output

18.1.6 USB port

Function	Formatting	Type
OTG capable	FAT, FAT32, exFat	Type A

Table 57 Specification USB port

18.1.7 RS485 Modbus

Protocol	Baudrate
Modbus RTU, Modbus ASCII	9600, 19200, 38400, 115200

Table 58 Specification RS485 Modbus

18.1.8 Outputs for internal use

The following outputs are used internally and cannot be used by the operator.

Digital input (DI4) – Encoder for motor speed

Type	Voltage	Current
Changeover contact	125 VAC / 60 VDC	1 A

Table 59 Specification Digital input (internal)

Analog output - Controlled output to the motor

Type of output	Type of signal	Resolution
Voltage output	0-10 VDC	16 bit
Current output	4-20 mA	16 bit
Pulse output	Pulses	200 pulses/min

Table 60 Specification analog output (internal)

18.1.9 Integrated evaluation unit for connecting em-tec flow sensors (option)

Device Type	em-tec BioProTT FlowMCP1-a
Working principle	Ultrasonic transit time flow measurement (TTFM)
Number of inputs sensor	1x for em-tec standard sensor cable with 16-pin round connector
Compatibility sensors	All clamp-on flow sensors of the em-tec BioProTT series
Power supply	24 VDC ($\pm 10\%$) internally supplied via the Q-Control pump
Analog outputs	2x (0) 4 – 20 mA Volume flow and RSS value Internally wired with the Q-Control pump
protocol	Modbus TCP (RJ-45 connection) Communication and web interface
Environmental and usage conditions	See data sheet for complete Q-Control pumps To be found in the standard Quattroflow instructions for the corresponding pump series

Table 61 Technical data em-tec FlowMCP1-a

Further technical data and information on measuring accuracy can be found in the data sheets from em-tec.

18.1.10 Integrated evaluation unit for connecting PendoTECH pressure sensors (option)

Device Typ	PendoTECH PressureMAT Sensor Transmitter PT-60
Working principle	Relative pressure measurement
Measuring range	4 - 20 mA: 0 - 4,14 barg Complete range: -0.63 ... 4.76 barg
Number of inputs sensor	1x for PendoTECH standard sensor cable with flat plug (white) *
Compatibility sensors	All PendoTECH single-use pressure sensors
Power supply	9 – 36 VDC Internally supplied via the Q-Control pump
Analog output	(0) 4 – 20 mA Internally wired with the Q-Control pump

Table 62 Technical data PendoTECH PT-60

* **Note on the cable / connector:** if the single-use pressure sensor is equipped with a waterproof circular connector for panel mounting, a corresponding adapter cable must be used, which is available from PendoTECH.

Further technical data and information on measuring accuracy can be found in the PendoTECH data sheets.

18.2 Parameter table and standard values

The following tables show the standard factory values for various Quattroflow pumps. A total of 8 different parameter sets are present, based on the pump series and the eccentric shaft. There is no differentiation between multiple-use and single-use pumps.

NOTE

The pumps with Q-Control are parameterized independently of the scope of supply (e.g., sensors, membrane monitoring). Initial setup and configuration with the corresponding sensors must be performed by the user.

Tab	Parameter	Unit	Values	QF30	QF150	QF1200	QF2500	QF4400 QF5K
Dispense	Unit		ml, l, gal	ml	ml	l	l	l
	Volume		numeric value	25	100	1.0	1.0	2.0
	Cycles		1 ... 999	3				
	Run	s	numeric value	10.0				
	Wait	s	numeric value	10.0				
Parameter 1	Language		German, English Chinese	English				
	Unit F Unit F		mIPM, LPM, LPH, GPM	mIPM	LPM	LPM	LPM	LPM
	Unit P Unit P		bar, PSI	bar				
	Cal	ml/rev	numeric value	<i>See table below</i>				
	Slope	%/s	numeric value	50	50	50	30	30
Manual modes	Totalizer		Yes, No	No				
	Input		Internal, Sensor	Internal				
	Reset		Ok?					
Max values	Max RPM	RPM	numeric value	1000	3000	2400	1800	1200
	Max F	Parameter 1 > Unit F	numeric value	<i>See table below</i>				
	Max P	Parameter 1 > Unit F	numeric value	4.0				
USB Logging	Active		On, Off	Off				
	Decimal		. ,	,				
	Interval	s	numeric value	1.0				
Modbus RS485	Protocol		RTU, ASCII	RTU				

	Address		1 ... 255	1	
	Baudrate		9600, 19200, 38400, 115200	9600	
	Parity		No, even, odd	No	
Parameter 2	Screensaver	Minute	1 ... 600	5	
	PIN Code		00000 ... 99999	00000	
External control	External RPM		AIN1, AIN2, AIN3, AIN4, Off	Off	
	Start/Stop		AIN1, AIN2, AIN3, AIN4, DIN1, DIN2, DIN3, Off	Off	
	Threshold	mA		AIN1,2,3: 4,1...20mA	4.1 mA
		V		AIN4: 0.1...10V	0.1 V
	Ext Trigger		Yes, No	No	
Keylock		On, off	Off		
Sensor mapping	Flow		AIN1, AIN2, AIN3, AIN4, Off	Off	
	Pressure		AIN1, AIN2, AIN3, AIN4, Off	Off	
Analog input 1	Signal type		4-20 mA	4-20 mA	
	Type		Raw, Flow, Pressure, em- tec, P-TECH	Raw	
	Unit		mlPM, LPM, LPH, GPM bar, PSI	LPM bar	
	Min value		numeric value	0	
	Max value		numeric value	0	
	Alarm		numeric value	0	
Analog input 2	Signal type		4-20 mA	4-20 mA	
	Type		Raw, Flow, Pressure, em- tec, P-TECH	Raw	
	Unit		mlPM, LPM, LPH, GPM bar, PSI	LPM bar	
	Min value		numeric value	0	
	Max value		numeric value	0	
	Alarm		numeric value	0	
Analog input 3	Signal type		4-20 mA	4-20 mA	
	Type		Raw, Flow, Pressure, em- tec, P-TECH, RSS	Raw	

	Unit		mIPM, LPM, LPH, GPM bar, PSI	LPM bar
	Min value		numeric value	0
	Max value		numeric value	0
	Alarm		numeric value	0
Analog input 4	Signal type		0-10 V	0-10V
	Type		Raw, Flow, Pressure, RSS	Raw
	Unit		mIPM, LPM, LPH, GPM bar, PSI	LPM bar
	Min value		numeric value	0
	Max value		numeric value	0
	Alarm		numeric value	0
Alarms analog	Analog 1		On, off	Off
	Analog 2		On, off	Off
	Analog 3		On, off	Off
	Analog 4		On, off	Off
Alarms digital	Digital 1		On, off	Off
	Digital 2		On, off	Off
	Digital 3		On, off	Off
DIN inverted	Digital 1		On, off	Off
	Digital 2		On, off	Off
	Digital 3		On, off	Off
Analog output	Type		Off, 4-20 mA	Off
PID Flow Control	Kp		numeric value	0.4
	Ki		numeric value	0.2
	Kd		numeric value	0
	AT Start	%	0 ... 100	30
	AT Delta	%	0... 100	15
PID Pressure Control				<i>See PID Flow Control</i>

Table 63 Standard parameters part 1

Pump type	QF30	QF150		QF1200	
Eccentric shaft	3°	3°	5°	3°	5°
Parameter: Cal [ml/rev]	0,55	0,72	1,20	5,90	9,80
Parameter: Max F	500	1,67	3,0	13,3	20,0
Unit based on <i>Parameter 1 > Unit F</i>	mIPM	LPM	LPM	LPM	LPM

Table 64 Standard parameters part 2

Pumpentyp	QF2500	QF4400		QF5K
Exzenterwelle	5°	3°	5°	5°
Parameter: Cal [ml/rev]	27,00	52,00	95,00	91,00
Parameter: Max F	41,7	41,7	83,3	100,0
Unit based on: <i>Parameter 1 > Unit F</i>	LPM	LPM	LPM	LPM

Table 65 Standard parameters part 3

18.3 Predefined manufactory parameters

The following parameters are configured in the software by the manufacturer for the specific pump when shipped and cannot be changed by the user.

These values influence the upper limits of the following parameters, which can be changed by the customer:

MENU > Max values > Max. RPM

MENU > Parameter 1 > Slope

The minimum rotation speed is for example used for the operating mode Manual RPM and Manual Flow.

Parameter	QF30	QF150	QF1200	QF2500	QF4400	QF5K
Max. Speed [UPM]	1000	3000	2400	1800	1200	1200
Min. Speed [RPM]	1	10	10	20	10	13
Max. Slope [%/s]	50	50	50	30	30	30

Table 66 Standard parameter manufacturer

19 Units and abbreviations

Units / Symbol	Description
mIPM	Milliliters per minute. Unit for volume flow with the unit [ml/min]
LPM	Liters per minute. Unit for volume flow with the unit [l/min]
LPH	Liter per hour Unit for volume flow with the unit [l/min]
GPM	US gallons per minute. Unit for volume flow with the unit [gal/min] US gallon = 3.785 Liter
bar	Main unit for pressure If not otherwise indicated, backpressure (differential pressure) has the unit [barg].
PSI	Main unit for pressure PSI = 0.069 bar If not otherwise indicated, backpressure (differential pressure) has the unit [PSIG].
ml	Milliliter. Unit for volume.
l	Liter. Unit for volume.
gal	US-Gallone. Unit for volume. US gallon = 3.785 Liter
RPM	Speed [1/min] Rotations per Minute
s	Second. Time unit
mA	Milliampere. Unit for electrical current
V	Volt. Unit for voltage.
rev	Rev = Revolution DE: Revolution
F	Flow / Fluss
P	Pressure
AIN / AI	Analog input
AO	Analog output
DIN / DI	Digital input
DO	Digital output
Total	Totalizer
RSS	Received Signal Strength (for integrated option em-tec flow sensor)
P-TECH	PendoTECH (for integrated option PendoTECH pressure sensor)

Table 67 Units and abbreviations

20 Revision history operating manual

Rev	Date	Changes from previous version / comment
1	November 2021 Software-Version: 02.XX.XX	<p>General adaption</p> <ul style="list-style-type: none"> ▪ Miscellaneous minor corrections ▪ Miscellaneous pictures and tables updated ▪ Missing Standard-Parameter for QF2500-QCON and QF4400-QCON added ▪ New Pump Series QF5K-QCON added ▪ New note for batterie disposal <p>New Software-Version 02.XX.XX</p> <p>Added support for new pump types with integrated em-tec / PendoTECH option (QCON...-EP/-E/-P)</p> <ul style="list-style-type: none"> ▪ New chapters for usage of em-tec and PendoTECH sensors ▪ New types in analog-inputs (em-tec, P-TECH, RSS) ▪ Adapted alarm limits ▪ Implemented support for RSS-value (for em-tec only) ▪ Connections and wiring diagrams updated ▪ Negative measuring values can be displayed ▪ Extrapolation of measuring values into the negative area (>4mA) and positive area (>20mA) up to the alarm-limits ▪ PID-Alarm for wrong sensor position <p>New functions</p> <ul style="list-style-type: none"> ▪ Chinese language pack ▪ Conversation between QF30QCON/QF150QCON pumps ▪ Compatibility check of the config version during import ▪ Adapted Firmware-Update and loading of the standard configuration ▪ Display and USB-logging of invalid measuring values ▪ Display of the measuring values of the analog-inputs during operation ▪ Factory reset <p>Adapted functions</p> <ul style="list-style-type: none"> ▪ Sensor-Alarm / Sensor-Monitoring ▪ Parameter Max RPM ▪ RS485: Setpoints and Start/Stop commands can now be written in all operation modes at any time <p><i>More information about new Software-Version can be found in the Software Change Log (available on request)</i></p>
0	November 2020 Software-Version: 01.XX.XX	<p>Initial version Launch of Q-Control Pump Series</p>

Table 68 Revision history operating manual

The information contained in this document was checked for correctness and completeness at the time of publication. The product data may change without prior notice.

Quattroflow™ is a brand of PSG Germany GmbH since April 2020.
(formerly ALMATEC Maschinenbau GmbH)



PSG Germany GmbH
Hochstraße 150-152· D-47228 Duisburg, Germany
Phone: +49 (0) 2065 89205-0 · Fax: +49 (0) 2065 89205-40
www.quattroflow.com · psg-germany@psgdover.com